

**PANAMA CITY TV LLC  
220 Salters Creek Road  
Hampton, VA 23661**

---

May 6, 2024

Via Upload to Public Inspection File Only

Elizabeth E. Goldin  
Assistant Chief, Investigations & Hearings Division  
Enforcement Bureau  
Federal Communications Commission  
45 L Street NE  
Washington, DC 20554

**Re: EEO Audit Response  
WPGX, Panama City, FL (Facility Id: 2942)**

Dear Ms. Goldin:

This letter, together with attached **Exhibits 1 through 6**, serves as the response by Panama City TV LLC (the “Licensee”), licensee of WPGX, Panama City, Florida, FCC Facility ID No. 2942 (“WPGX” or the “Unit”), to the Enforcement Bureau’s request for audit data relating to the Station’s EEO program dated March 22, 2024.

The responses to the relevant audit data requests are set forth below, and the required documentation is provided in the attached Exhibits.

In accordance with the Bureau’s request for audit data, this response has been uploaded to the online public inspection file of each station in the Unit.

\*\*\*\*\*

***Audit Data Request 2(b)(1).*** *[Provide] [c]opies of the Unit’s two most recent EEO Public File Reports, described in section 73.2080(c)(6). For each station in the Unit that maintains a website, provide the website address. If the Unit’s most recent EEO Public File Report is not posted on each website as required by section 73.2080(c)(6), identify that website and explain why the report is not so posted. If the Unit does not maintain a website, but its corporate site contains a link to a site pertaining to the Unit, identify the corporate website address where the Unit’s most recent EEO Public File Report is linked pursuant to section 73.2080(c)(6).*

**Response:** The Unit’s EEO Public File Reports covering October 1, 2021, through September 30, 2022, and October 1, 2022, through September 30, 2023, are attached as **Exhibits 1 and 2**, respectively.

The Unit’s website is located at *wpgxfox28.com*. On the website, the Unit’s most recent EEO Public File Report is, and at all relevant times has been, available at the bottom of each page of the website, as shown in the screen capture below:

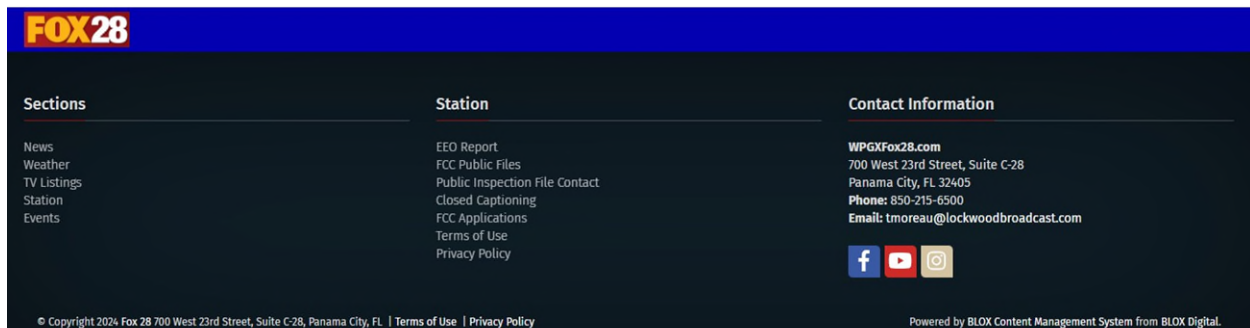

Clicking on the link above titled “EEO Report” directs viewers to the Unit’s most recent EEO Public File Report. Current and past EEO Public File Reports are also available by clicking the “FCC Public Files” link, which directs viewers to the online public file of WPGX.

\*\*\*\*\*

***Audit Data Request 2(b)(ii).*** For each of the Unit’s full-time positions filled during the period covered by the EEO Public File Reports noted above, or since acquisition of the Unit (if during that period), provide the date of hire as required by section 73.2080(c)(5)(vi) as well as dated copies of all advertisements, bulletins, letters, faxes, e-mails or other communications announcing the position, as described in section 73.2080(c)(5)(iii). However, to reduce the burden of responding to this audit, if you have sent a job notice to multiple sources, you may include in your response: (1) documentation showing one such notice was sent, (2) a list of the additional sources to which the notice was distributed, and (3) a statement confirming notices to all additional sources used to announce the vacancy were retained, as required by section 73.2080(c)(5)(iii). Include, however, copies of all job announcements sent to any organization (identified separately from other sources) that has notified the Unit that it wants to be notified of the Unit’s job openings, as described in section 73.2080(c)(1)(ii).

**Response:** During the relevant period, the Unit filled two (2) full-time positions on the indicated dates.

Position number	Position Filled	Date Filled
1	Account Executive	5/16/2022
2	Account Executive	7/5/2023

For each job opening, the Unit has attached (as **Exhibits 3 and 4** respectively) copies of advertisements, bulletins, letters, faxes, emails, or other communications announcing the job opening, which have been retained as required by Section 73.2080(c)(5)(iii). The material provided in each Exhibit demonstrates wide dissemination of information about each vacancy.

No organizations have notified the Unit that they want to be notified of Unit job openings.

\*\*\*\*\*

**Audit Data Request 2(b)(iii).** *As required by section 73.2080(c)(5)(v), [provide] the total number of interviewees for each vacancy and the referral source for each interviewee for all of the Unit’s full-time vacancies filled during the period covered by the above-noted EEO Public File Reports.*

**Response:** The total number of interviewees for each vacancy and the referral source for each interviewee for all full-time vacancies filled during the applicable period are as follows:

Position number	Position Filled	Date Filled	Number of Interviewees	Referral Sources for Interviewees
1	Account Executive	5/16/2022	3	- Indeed.com - Internal Referral
2	Account Executive	7/5/2023	1	- Internal Referral

\*\*\*\*\*

**Audit Data Request 2(b)(iv).** *[Provide] [d]ated documentation of the Unit’s recruitment initiatives described in section 73.2080(c)(2) during the period covered by the above-noted EEO Public File Reports, such as participation in job fairs, events with educational institutions, and mentoring or training programs for staff. Specify the Unit personnel involved in each recruitment initiative. In addition, provide the Unit’s total number of full-time employees and state whether the population of the market in which any of the Unit’s stations operates is 250,000 or more. Based upon these two factors and as required by sections 73.2080(c)(2) and (e)(3) of the Commission’s rules, state whether the Unit is required to perform two or four points worth of initiative activities within a two-year period (measured from the date the*

*stations in the Unit file their renewal applications and the second, fourth, sixth and eighth anniversaries of that date). If the Unit performed more than the required number of initiative activities, it may provide documentation for only the required amount in its response, i.e., two or four points worth. If any documentation that you provide appears inadequate, e.g., it is not dated or does not clearly prove the Unit's participation, the Commission may ask you for additional verification.*

**Response:** The Unit has 9 full-time employees as of May 1, 2024. The city of license for the Unit, Panama City, Florida, is located in a Metropolitan Statistical Area with fewer than 250,000 people. According, the Unit is required to perform two (2) initiatives in each applicable two-year period.

During the period of time covered by the two most recent EEO File Reports, the Unit engaged in more than two (2) outreach initiatives, including those described below, and has attached, as **Exhibits 5 and 6**, documentation demonstrating performance of the same:

<b>General Outreach Program (47 C.F.R. § 73.2080(c)(2)(vi))</b>	
<b>Exhibit 5</b>	
<i>Activity</i>	<i>Personnel Involved</i>
WPGX created and aired announcements that encouraged viewers interested in pursuing a radio and/or television career to utilize the websites of the Florida Association of Broadcasters to learn of employment opportunities at member stations. These announcements ran throughout the reporting period on WPGX.	Production Department

<b>Training of Station Personnel (47 C.F.R. § 73.2080(c)(2)(viii))</b>	
<b>Exhibit 6</b>	
<i>Activity</i>	<i>Personnel Involved</i>
<p>- In the Spring of 2022, the General Manager and Sales Manager participated in WideOrbit Marketplace training to help the station grow revenue options.</p> <p>- Account Executive participated in Jim Doyle trainings from December 16, 2021 through July 6, 2022. Trainings included items such as prospecting, closing business, jump starting your career, and avoiding common issues and objections to pitches. The program included items for new sellers and experienced Account Executives.</p> <p>- March 29, 2023: The entire sales team participated in digital sales training with Orbit Interactive, the station’s digital partner, in order to learn about the Orbit Interactive product suite, how to customize the product for local advertisers, and learn the basics of digital language.</p> <p>- August 25, 2023, September 1, 2023, September 8, 2023, and September 15, 2023: The sales team and managers met with Jason Schlitz from Orbit Interactive each Friday to train on digital sales tools. Training included items such as display products and conversions, dashboard navigation and order entry, and new AI creative tools.</p> <p>- September 18, 2023: The sales team and managers worked with TVB presenter Brian Wexler to train on preparing for the TVB sales seminar with local clients scheduled for October 17, 2023. The training discussed topics such as creating the presentation and targeting in demand industries.</p>	<p>Various Station Management and Employees</p>

\*\*\*\*\*

***Audit Data Request 2(b)(v).*** *Disclose any pending or resolved complaints involving the Unit filed during the Unit's current license term(s) before any body having competent jurisdiction under federal, state, territorial or local law, alleging unlawful discrimination in the employment practices of the Unit on the basis of race, color, religion, national origin, or sex. For each such complaint, provide: (1) a brief description of the allegations and issues involved; (2) the names of the complainant and other persons involved; (3) the date the complaint was filed; (4) the court or agency before which it is pending or by which it was resolved; (5) the file or case number; and (6) the disposition and date thereof or current status. Note that you must report all complaints, regardless of their status or disposition.*

**Response:** There are no such pending or resolved complaints during the specified time period.

\*\*\*\*\*

***Audit Data Request 2(b)(vi).*** *In accordance with section 73.2080(b), during the Unit's current license term(s) (or since acquisition of the Unit (if during that period)), describe the responsibilities of each level of Unit management responsible for implementing Unit EEO policies and describe how the Unit has informed employees and job applicants of its EEO policies and program.*

**Response: Enforcement of EEO Policies.** The Unit's General Manager, and the Unit's corporate President, Vice President of Operations, and Director of Business Services are responsible for ensuring enforcement of the Unit's EEO policies. Each has significant input into the hiring, firing, and supervision of station employees. Each is aware of the Licensee's responsibility to widely disseminate vacancy notifications to qualified applicants and monitor and enforce EEO policies on a continuing basis. The Director of Business Services routinely participates in trainings provided by the EEOC, Littler Mendelson P.C., and other organizations to stay on top of current EEOC rules and recommendations. This information is passed on to the Vice President of Operations and General Manager to ensure EEOC policies are enforced as changes are made. Periodically, the Vice President of Operations and Director of Business Services meet with the Unit's staff to discuss EEO policies and program issues. The Vice President of Operations monitors the interview process to ensure that the Unit's EEO policies are being followed. All hiring and firing must be approved by the Vice President of Operations.

*Unit's Efforts to Inform Employees and Applicants of EEO Policies and Program.* The Unit provides all Unit employees with an Employee Handbook containing the Unit's EEO policy. Each employee must sign forms stating that they have received a copy of and understand the EEO policy. The Unit also posts a poster

with a summary of applicable EEO laws in a common workspace. The Unit includes a statement on all job announcements and outreach letters that it is an Equal Opportunity Employer, and includes an EEO statement on its website at [wpgxfox28.com/stations/jobs\\_internships/](http://wpgxfox28.com/stations/jobs_internships/).

\*\*\*\*\*

***Audit Data Request 2(b)(vii).*** *In accordance with section 73.2080(c)(3), during the Unit's current license term(s) (or since acquisition of the Unit (if during that period)), describe the Unit's efforts to analyze its EEO recruitment program to ensure that it is effective and to address any problems found as a result of such analysis.*

**Response:** The Unit continually monitors and analyzes its EEO recruitment program. Unit management maintains and updates its recruitment source list, adding new sources and contact information as warranted. Recruitment sources are routinely added to and revised based upon the specific position being recruited for and recent success identifying viable candidates through each source in prior recruitment efforts.

In conjunction with its ongoing analysis of its performance of outreach initiatives, the Unit sought variety in its outreach activities over the applicable two-year period. These efforts are made as a result of the Unit's evaluation and analysis of its outreach initiatives and in an effort to inform and reach a broader and more varied segment of the community.

\*\*\*\*\*

***Audit Data Request 2(b)(viii).*** *As required by section 73.2080(c)(4), during the Unit's current license term(s) (or since acquisition of the Unit (if during that period)), describe the Unit's efforts to analyze periodically its measures taken to examine pay, benefits, seniority practices, promotions, and selection techniques and tests to ensure that they provide equal opportunity and do not have a discriminatory effect. If the Unit has one or more union agreements, describe how the Unit cooperates with each union to ensure EEO policies are followed for the Unit's union-member employees and job applicants.*

**Response: Compensation and Benefit Levels.** The Unit's compensation levels for all employees are reviewed on a regular basis by the Vice President of Operations and the General Manager to ensure the levels provide equal opportunities for all employees and do not have a discriminatory effect. Compensation may be increased for myriad reasons, including merit, fairness, and to ensure that rates of pay are non-

discriminatory. Compensation is also reviewed annually by the Unit's corporate officers.

*Seniority Practices and Promotions.* The Vice President of Operations and the General Manager also review Unit employees for promotions on a regular basis. Promotions and raises are determined based on the General Manager's assessment of the employee's performance and contributions to the Station.

*Selection Techniques.* After providing notices of job vacancies to a wide and diverse array of professional organizations, non-profits, and internet resources, the selection process is based upon the experience, qualifications, and talents of the candidates. The General Manager then consults with the Vice President of Operations on each selection.

*Union Cooperation.* The Unit is not a party to a union agreement.

\*\*\*\*\*

The remaining audit data requested is not applicable. The Licensee is not a religious broadcaster, and WPGX is not brokered.

If you have any questions regarding this response or need any further information, please contact our communications counsel, Noah L. Hock, at [nhock@brookspierce.com](mailto:nhock@brookspierce.com) or (336) 271-3177.

The undersigned, under penalty of perjury, declares the foregoing to be true, complete, and correct to the best of their personal knowledge

This, the 6<sup>th</sup> day of May, 2024.

By: 

Gerald Walsh  
Vice President



**Exhibit 1**

EEO Public File Report  
October 1, 2021 through September 30, 2022

[Attached]

EEO PUBLIC FILE REPORT

FOR

**WPGX-TV**

This EEO Public File Report  
October 1, 2021 to September 30, 2022

## **EEO Annual Public File Report**

### **WPGX-TV**

The purpose of this EEO Public File Report is to comply with Section 73.2080 (c)(6) of the Federal Communications Commission's EEO Rule. This Report has been prepared on behalf of WPGX. This Report will be placed in WPGX's public inspection file and posted on WPGX's website.

The information contained in this Report covers the time period ending September 30, 2022 (the "Reporting Period").

Attachments 1 through 3 are intended to provide the information required by the FCC's EEO Rule. Attachments 1 and 2 contain the following information for each full-time vacancy:

- \* The recruitment source(s) used to fill each vacancy, identified by name, address, contact person and telephone number;
- \* The recruitment source that referred the hiree for each full-time vacancy;
- \* The total number of persons interviewed for each full-time vacancy; and,
- \* The total number of interviewees referred by each recruitment source used in connection with each vacancy.

Attachment 3 contains a list and brief description of outreach initiatives undertaken pursuant to the FCC's EEO Rule during the Reporting Period.

Questions concerning this Report should be directed to Tiffany Humphrey at (804) 672-6565.

\* \* \* \* \*

### **ATTACHMENT 1**

**FULL-TIME VACANCY INFORMATION**

<b>Position Title</b>	<b>Total No. Interviewees for the Vacancy</b>	<b>Recruitment Source of Hiree</b>	<b>Recruitment Sources Utilized (see attached list of sources)</b>
Account Executive	3	1	1-16

Total number of persons interviewed during the Reporting Period: 3

**ATTACHMENT 2**  
**RECRUITMENT SOURCE INFORMATION**

<b>Recruitment Source (see attached list)</b>	<b>Total Number of Interviewees from Source*</b>	<b>Did Source Request Notice of Job Openings?</b>
<b>1</b>	<b>1</b>	<b>No</b>
<b>2</b>	<b>0</b>	<b>No</b>
<b>3</b>	<b>0</b>	<b>No</b>
<b>4</b>	<b>0</b>	<b>No</b>
<b>5</b>	<b>0</b>	<b>No</b>
<b>6</b>	<b>0</b>	<b>No</b>
<b>7</b>	<b>0</b>	<b>No</b>
<b>8</b>	<b>0</b>	<b>No</b>
<b>9</b>	<b>0</b>	<b>No</b>
<b>10</b>	<b>0</b>	<b>No</b>
<b>11</b>	<b>0</b>	<b>No</b>
<b>12</b>	<b>0</b>	<b>No</b>
<b>13</b>	<b>0</b>	<b>No</b>
<b>14</b>	<b>0</b>	<b>No</b>
<b>15</b>	<b>0</b>	<b>No</b>
<b>16</b>	<b>2</b>	<b>No</b>

## RECRUITMENT SOURCES

### Source

1. Internal Referral
2. Employ Florida [www.employflorida.com](http://www.employflorida.com)
3. TV Jobs [www.tvjobs.com](http://www.tvjobs.com) POB 4116 Oceanside, CA 92052 (800) 374-0119 [info@tvjobs.com](mailto:info@tvjobs.com)
4. Career Source Gulf Coast Center –  
<https://www.employflorida.com/vosnet/Default.aspx?enc=vLa15KtdCzQQMP6jrcRdIQ> 1310 E 11th St, Panama City, FL 32401 850-872-4340
5. Bay County Chamber of Commerce 235 W. 5<sup>th</sup> Street Panama City, FL 32401 [taylor@baychamberfl.com](mailto:taylor@baychamberfl.com) Taylor Smith 850-215-3755
6. Catholic Charities “Bridges to Circles of Bay County” 3128 E 11<sup>th</sup> Street Panama City, FL 32401 [sharpn@cc.ptdiscese.org](mailto:sharpn@cc.ptdiscese.org) Naomi Sharp 850-763-0475 X1030
7. Florida Assoc. of Broadcasters 201 S. Monroe Street #201 Tallahassee, FL 32301 [lvarn@fab.org](mailto:lvarn@fab.org) L. Varn 850-681-4444 or 800-825-5322
8. Goodwill IND Career Training Center 300 Mabry Street Tallahassee, FL 32304 [sburnett@goodwillbigbend.com](mailto:sburnett@goodwillbigbend.com) Steven Burnett 850-522-3900
9. Haney Technical Center 3016 FL-77 Panama City, FL 32405 [nixkd@bay.k12.fl.us](mailto:nixkd@bay.k12.fl.us) Kim Nix 850-767-5500
10. Kelly Services 2408 Lisenby Avenue Panama City, FL 32405 [2053@kellyservices.com](mailto:2053@kellyservices.com) 850-785-1566
11. Mississippi Assoc. of Broadcasters 855 S. Pearl Orchard Road #403 Ridgeland, MS 39157  
[email@msbroadcasters.org](mailto:email@msbroadcasters.org) 601-957-9121
12. Navy Transition Assistance and Family Employment [Tiffany.parton.ctr@navy.mil](mailto:Tiffany.parton.ctr@navy.mil) Tiffany Parton 850-235-5611
13. Panama City Beach Chamber of Commerce 309 Richard Jackson Boulevard #101 Panama City, FL 32407  
[shannon@pcbeach.org](mailto:shannon@pcbeach.org) Shannon Richmond 850-890-8069
14. Snelling Personnel Services 1420 Airport Road Panama City, FL 32405 [ruth\\_burton@yahoo.com](mailto:ruth_burton@yahoo.com) Ruth Burton 850-769-1441
15. St. John Baptist Church 1021 Martin Luther King Jr. Boulevard Panama City, FL 32401 [stjohnmiss@comcast.net](mailto:stjohnmiss@comcast.net) 850-747-1269
16. Indeed.com

### ATTACHMENT 3

#### MENU OPTION ACTIVITIES

WPGX-TV has engaged in the following outreach activities during the period covered by this Report:

Activity Classification*	Type of Activity	Brief Description
6	Participation in job banks, Internet programs, and other programs designed to promote outreach generally (i.e., outreach that is not primarily directed to providing notification of specific job vacancies)	WPGX created and aired announcements that encouraged viewers interested in pursuing a radio and/or a television career to utilize the websites of the Florida Association of Broadcasters to learn of employment opportunities at member stations. These announcements ran throughout the year on WPGX.
8	Establishment of training programs designed to enable station personnel to acquire skills that could qualify them for higher level positions;	<ul style="list-style-type: none"><li>• In the Spring of 2022, the General Manager and Sales Manager participated in WideOrbit Marketplace training to help station grow revenue options.</li><li>• Account Executive participated in Jim Doyle trainings from December 16, 2021 through July 6, 2022. Trainings included items such as prospecting, closing business, jump starting your career, and avoiding common issues and objections to pitches. The program included items for new sellers and experienced Account Executives.</li></ul>

\* For "Activity Classification", use "1" through "16" in accordance with attached list.

## Menu Option Classifications

1. Participation in at least four job fairs by station personnel who have substantial responsibility in making hiring decisions;
2. Hosting of at least one job fair;
3. Co-sponsoring of at least one job fair with organizations in the business and professional community whose membership includes substantial participation by women and minorities;
4. Participation in at least four events, including conventions, career days, workshops, and similar activities, sponsored by organizations representing groups present in the community interested in broadcast employment issues;
5. Establishment of an internship program designed to assist members of the community to acquire skills needed for broadcast employment;
6. Participation in job banks, Internet programs, and other programs designed to promote outreach generally (i.e., outreach that is not primarily directed to providing notification of specific job vacancies);
7. Participation in scholarship programs designed to assist students interested in pursuing a career in broadcasting;
8. Establishment of training programs designed to enable station personnel to acquire skills that could qualify them for higher level positions;
9. Establishment of a mentoring program for station personnel;
10. Participation in at least four events or programs sponsored by educational institutions relating to career opportunities in broadcasting;
11. Sponsorship of at least two events in the community designed to inform and educate members of the public about employment opportunities in broadcasting;
12. Listing of each upper-level category opening in a job bank or newsletter of media trade groups whose membership includes substantial participation by women and minorities;
13. Provision of assistance to unaffiliated non-profit entities in the maintenance of web sites that provide counseling on the process of searching for broadcast employment and/or other career development assistance pertinent to broadcasting;
14. Provision of training to management level personnel as to methods of ensuring equal employment opportunity and preventing discrimination;
15. Provision of training to personnel of unaffiliated non-profit organizations interested in broadcast employment opportunities that would enable them to better refer job candidates for broadcast positions;
16. Participation in other activities designed by the station reasonably calculated to further the goal of disseminating information as to employment opportunities in broadcasting to job candidates who might otherwise be unaware of such opportunities.



**Exhibit 2**

EEO Public File Report  
October 1, 2022 through September 30, 2023

[Attached]

EEO PUBLIC FILE REPORT

FOR

**WPGX-TV**

This EEO Public File Report  
October 1, 2022 to September 30, 2023

## **EEO Annual Public File Report**

### **WPGX-TV**

The purpose of this EEO Public File Report is to comply with Section 73.2080 (c)(6) of the Federal Communications Commission's EEO Rule. This Report has been prepared on behalf of WPGX. This Report will be placed in WPGX's public inspection file and posted on WPGX's website.

The information contained in this Report covers the time period ending September 30, 2023 (the "Reporting Period").

Attachments 1 through 3 are intended to provide the information required by the FCC's EEO Rule. Attachments 1 and 2 contain the following information for each full-time vacancy:

- \* The recruitment source(s) used to fill each vacancy, identified by name, address, contact person and telephone number;
- \* The recruitment source that referred the hiree for each full-time vacancy;
- \* The total number of persons interviewed for each full-time vacancy; and,
- \* The total number of interviewees referred by each recruitment source used in connection with each vacancy.

Attachment 3 contains a list and brief description of outreach initiatives undertaken pursuant to the FCC's EEO Rule during the Reporting Period.

Questions concerning this Report should be directed to Tiffany Humphrey at (804) 672-6565.

\* \* \* \* \*

### **ATTACHMENT 1**

**FULL-TIME VACANCY INFORMATION**

<b>Position Title</b>	<b>Total No. Interviewees for the Vacancy</b>	<b>Recruitment Source of Hiree</b>	<b>Recruitment Sources Utilized (see attached list of sources)</b>
Account Executive	1	1	1-15

Total number of persons interviewed during the Reporting Period: 1

**ATTACHMENT 2**  
**RECRUITMENT SOURCE INFORMATION**

<b>Recruitment Source (see attached list)</b>	<b>Total Number of Interviewees from Source*</b>	<b>Did Source Request Notice of Job Openings?</b>
<b>1</b>	<b>1</b>	<b>No</b>
<b>2</b>	<b>0</b>	<b>No</b>
<b>3</b>	<b>0</b>	<b>No</b>
<b>4</b>	<b>0</b>	<b>No</b>
<b>5</b>	<b>0</b>	<b>No</b>
<b>6</b>	<b>0</b>	<b>No</b>
<b>7</b>	<b>0</b>	<b>No</b>
<b>8</b>	<b>0</b>	<b>No</b>
<b>9</b>	<b>0</b>	<b>No</b>
<b>10</b>	<b>0</b>	<b>No</b>
<b>11</b>	<b>0</b>	<b>No</b>
<b>12</b>	<b>0</b>	<b>No</b>
<b>13</b>	<b>0</b>	<b>No</b>
<b>14</b>	<b>0</b>	<b>No</b>
<b>15</b>	<b>0</b>	<b>No</b>

## RECRUITMENT SOURCES

### Source

1. Internal Referral
2. Employ Florida [www.employflorida.com](http://www.employflorida.com)
3. TV Jobs [www.tvjobs.com](http://www.tvjobs.com) POB 4116 Oceanside, CA 92052 (800) 374-0119 [info@tvjobs.com](mailto:info@tvjobs.com)
4. Career Source Gulf Coast Center –  
<https://www.employflorida.com/vosnet/Default.aspx?enc=vLa15KtdCzQQMP6jrcRdIQ> 1310 E 11th St, Panama City, FL 32401 850-872-4340
5. Bay County Chamber of Commerce 235 W. 5<sup>th</sup> Street Panama City, FL 32401 [taylor@baychamberfl.com](mailto:taylor@baychamberfl.com) Taylor Smith 850-215-3755
6. Catholic Charities “Bridges to Circles of Bay County” 3128 E 11<sup>th</sup> Street Panama City, FL 32401  
[sharpn@cc.ptdiscese.org](mailto:sharpn@cc.ptdiscese.org) Naomi Sharp 850-763-0475 X1030
7. Florida Assoc. of Broadcasters 201 S. Monroe Street #201 Tallahassee, FL 32301 [lvarn@fab.org](mailto:lvarn@fab.org) L. Varn 850-681-4444 or 800-825-5322
8. Goodwill IND Career Training Center 300 Mabry Street Tallahassee, FL 32304 [sburnett@goodwillbigbend.com](mailto:sburnett@goodwillbigbend.com)  
Steven Burnett 850-522-3900
9. Haney Technical Center 3016 FL-77 Panama City, FL 32405 [nixkd@bay.k12.fl.us](mailto:nixkd@bay.k12.fl.us) Kim Nix 850-767-5500
10. Kelly Services 2408 Lisenby Avenue Panama City, FL 32405 [2053@kellyservices.com](mailto:2053@kellyservices.com) 850-785-1566
11. Mississippi Assoc. of Broadcasters 855 S. Pearl Orchard Road #403 Ridgeland, MS 39157  
[email@msbroadcasters.org](mailto:email@msbroadcasters.org) 601-957-9121
12. Navy Transition Assistance and Family Employment [Tiffany.parton.ctr@navy.mil](mailto:Tiffany.parton.ctr@navy.mil) Tiffany Parton 850-235-5611
13. Panama City Beach Chamber of Commerce 309 Richard Jackson Boulevard #101 Panama City, FL 32407  
[shannon@pcbeach.org](mailto:shannon@pcbeach.org) Shannon Richmond 850-890-8069
14. Snelling Personnel Services 1420 Airport Road Panama City, FL 32405 [ruth\\_burton@yahoo.com](mailto:ruth_burton@yahoo.com) Ruth Burton  
850-769-1441
15. St. John Baptist Church 1021 Martin Luther King Jr. Boulevard Panama City, FL 32401 [stjohnmiss@comcast.net](mailto:stjohnmiss@comcast.net)  
850-747-1269

## ATTACHMENT 3

### MENU OPTION ACTIVITIES

WPGX-TV has engaged in the following outreach activities during the period covered by this Report:

Activity Classification*	Type of Activity	Brief Description
6	Participation in job banks, Internet programs, and other programs designed to promote outreach generally (i.e., outreach that is not primarily directed to providing notification of specific job vacancies)	WPGX created and aired announcements that encouraged viewers interested in pursuing a radio and/or a television career to utilize the websites of the Florida Association of Broadcasters to learn of employment opportunities at member stations. These announcements ran throughout the year on WPGX.
8	Establishment of training programs designed to enable station personnel to acquire skills that could qualify them for higher level positions;	<ul style="list-style-type: none"> <li>• March 29, 2023: The entire sales team participated in digital sales training with Orbit Interactive, the station’s digital partner, in order to learn about the Orbit Interactive product suite, how to customize the product for local advertisers, and learn the basics of digital language.</li> <li>• August 25, 2023, September 1, 2023, September 8, 2023, and September 15, 2023: The sales team and managers met with Jason Schlitz from Orbit Interactive each Friday to train on digital sales tools. Training included items such as display products and conversions, dashboard navigation and order entry, and new AI creative tools.</li> <li>• September 18, 2023: The sales team and managers worked with TVB presenter Brian Wexler to train on preparing for the TVB sales seminar with local clients scheduled for October 17, 2023. The training discussed topics such as creating the presentation and targeting in demand industries.</li> </ul>

\* For “Activity Classification”, use “1” through “16” in accordance with attached list.

## Menu Option Classifications

1. Participation in at least four job fairs by station personnel who have substantial responsibility in making hiring decisions;
2. Hosting of at least one job fair;
3. Co-sponsoring of at least one job fair with organizations in the business and professional community whose membership includes substantial participation by women and minorities;
4. Participation in at least four events, including conventions, career days, workshops, and similar activities, sponsored by organizations representing groups present in the community interested in broadcast employment issues;
5. Establishment of an internship program designed to assist members of the community to acquire skills needed for broadcast employment;
6. Participation in job banks, Internet programs, and other programs designed to promote outreach generally (i.e., outreach that is not primarily directed to providing notification of specific job vacancies);
7. Participation in scholarship programs designed to assist students interested in pursuing a career in broadcasting;
8. Establishment of training programs designed to enable station personnel to acquire skills that could qualify them for higher level positions;
9. Establishment of a mentoring program for station personnel;
10. Participation in at least four events or programs sponsored by educational institutions relating to career opportunities in broadcasting;
11. Sponsorship of at least two events in the community designed to inform and educate members of the public about employment opportunities in broadcasting;
12. Listing of each upper-level category opening in a job bank or newsletter of media trade groups whose membership includes substantial participation by women and minorities;
13. Provision of assistance to unaffiliated non-profit entities in the maintenance of web sites that provide counseling on the process of searching for broadcast employment and/or other career development assistance pertinent to broadcasting;
14. Provision of training to management level personnel as to methods of ensuring equal employment opportunity and preventing discrimination;
15. Provision of training to personnel of unaffiliated non-profit organizations interested in broadcast employment opportunities that would enable them to better refer job candidates for broadcast positions;
16. Participation in other activities designed by the station reasonably calculated to further the goal of disseminating information as to employment opportunities in broadcasting to job candidates who might otherwise be unaware of such opportunities.



**Exhibit 3**

Position 1: Account Executive  
Date Filled: 5/6/2022

<b>Recruitment Documentation Attached</b>	<b>Date</b>
Employ Florida advertisement	3/7/2022
Indeed.com advertisement	4/8/2022
TVJobs advertisement	4/8/2022
Outreach letters*	4/8/2022

\* A sample outreach letter is attached. Licensee confirms that substantially similar letters were sent to each of the recruitment sources listed in the EEO Public File Report for the relevant period, attached hereto as Exhibit 1.

Results View: **Summary** | Detailed

To sort on any column, click a column title.

#	Job Title	Employer Job Status	On-line Status	System Status	Created	Inactive After	Actual Close Date	Views	Applicants	Action	Select
11488812	Account Executive (AE)	Open and available	on-line	Open and available	8/2/2021	12/30/2022	N/A	18	0	<a href="#">Copy</a> <a href="#">Edit</a> <a href="#">Delete</a> <a href="#">Search by Job Criteria</a> <a href="#">Pre-fill Advanced Resume Search</a> <a href="#">Applicants</a> <a href="#">Preview</a> <a href="#">Template</a>	<input type="checkbox"/>

Page 1 of 1 Rows 100

1 Records Found

SEARCH CRITERIA: Internal jobs only and Complete jobs

Show all jobs (including inactive and expired)

## Job Summary

Position range in Panama City, FL Metropolitan Statistical Area

# \$20k - \$52k

Per year

## Account Executive (AE)

### Panama City TV LLC- WPGX Fox

Occupation: Advertising Sales Agents

Location: Panama City, FL - 32405 Positions available: 1

Job #: 11488812

Updated: 1/5/2022 Expires: 12/30/2022

Source: Employ Florida Site: Employ Florida

## Job Requirements

---



## Job Properties

---



## Job Description

## Job Description

WPGX-TV FOX 28 has openings for experienced Account Executives to manage and grow transactional business as well focusing on prospecting and closing new business. We are looking for a self-starter with proficiency in cold calling and creating and delivering presentations. Duties include but are not limited to:

- Develop and maintain direct relationships with agencies and clients while driving revenue to achieve monthly goals
- Close new and incremental business
- Understand and interpret business objectives and advertising strategies of clients in order to help them achieve those objectives through effective use of our product portfolio
- Prepare, schedule and deliver sales presentations

### Qualifications/Requirements:

- Must be willing to work in Panama City, FL
- Proficient in the operation of a computer keyboard
- Proficient in Microsoft Products including but not limited to Outlook, PowerPoint, Word and Excel
- **Good driving record**
- One-three years of television sales experience is preferred
- Bachelor's degree in advertising or marketing is preferred

### Skills and Abilities:

- Strong communication skills
- Excellent negotiation and customer service skills
- Team player, who is flexible to changing needs to daily business
- Ability to work in a rapid-pace environment

Lockwood Broadcast Group and WPGX-TV FOX 28 provides equal employment opportunities to all employees and applicants for employment and prohibits discrimination and harassment of any type without regard to race, color, religion, age, sex, national origin, disability status, genetics, protected veteran status, sexual orientation, gender identity or expression, or any other characteristic protected by federal, state or local laws. **Pre-employment drug test is required along with a background screen as allowed by federal, state, and local laws and regulations.**

## Employer Research

## Employer Research

Panama City TV LLC- WPGX Fox

Is a Private Sector employer with 2 locations

### Company Profile:

WPGX is the Fox Television Network affiliate for Panama City, Florida. Panama City is a Gulf Coast resort that draws visitors from all over the Southeast United States because of its amusement parks and excellent fishing. The city's industries produce paper, clothing, and chemicals. Tyndall Air Force Base and U.S. Naval Support Activity Panama City are nearby.

## Edit the job post

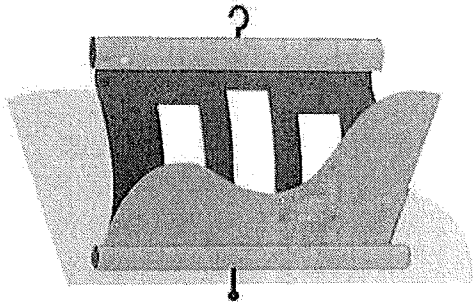

### Account Executive

WPGX Fox 28 

Panama City, FL 32405 

### Job details

#### Pay

\$12.00 - \$33.00 per hour

#### Job type

Full-time

#### Number of openings for this position

1

#### Schedule

Monday to Friday

#### Benefits

Health insurance

401(k)

Paid time off

Dental insurance

Vision insurance

Life insurance

## LIFE INSURANCE

Disability insurance

Flexible spending account

Employee assistance program

**Job description** 

WPGX-TV FOX 28 has openings for experienced Account Executives to manage and grow transactional business as well focusing on prospecting and closing new business. We are looking for a self-starter with proficiency in cold calling and creating and delivering presentations.

This position is salaried plus commission.

Duties include but are not limited to:

- Develop and maintain direct relationships with agencies and clients while driving revenue to achieve monthly goals
- Close new and incremental business
- Understand and interpret business objectives and advertising strategies of clients in order to help them achieve those objectives through effective use of our product portfolio
- Prepare, schedule and deliver sales presentations

## Qualifications/Requirements:

- Must be willing to work in Panama City, FL
- Proficient in the operation of a computer keyboard
- Proficient in Microsoft Products including but not limited to Outlook, PowerPoint, Word and Excel
- Good driving record
- One-three years of television sales experience is preferred
- Bachelor's degree in advertising or marketing is preferred

## Skills and Abilities:

- Strong communication skills
- Excellent negotiation and customer service skills
- Team player, who is flexible to changing needs to daily business
- Ability to work in a rapid-pace environment

Lockwood Broadcast Group and WPGX-TV FOX 28 provides equal employment opportunities to all employees and applicants for employment and prohibits discrimination and harassment of any type without regard to race, color, religion, age, sex, national origin, disability status, genetics, protected veteran status, sexual orientation, gender identity or expression, or any other characteristic protected by federal, state or local laws. Pre-

employment drug test is required along with a background screen as allowed by federal, state, and local laws and regulations.

Hide

**Supplemental pay** 

- Commission pay

**Work location** 

- On the road

**COVID-19 precautions** 

Mask requirement if not fully vaccinated. If fully vaccinated, proof of vaccines required

 **Photos and videos**

Photos and videos were not added and will not appear on the job post.

+ Add

**Settings**

The following information will not be shared on your job post.

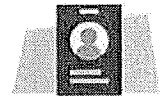

**Application settings**

**Apply method** 

- Email

**Resume required** 

- Yes

**Send application updates to** 

- dgiancola@wpgxfox28.com
- shgreene@wpgxfox28.com
- Also send an individual email update each time someone applies.

**Allow messages** 

- No, do not let people who apply to the job message about their application

**Employer Assist** 

- No, do not automatically decline candidates

**Customized pre-screening** 

- Application question: What is the highest level of education you have completed?

# Job Listing Preview



Broadcast Employment Services

## WPGX (FOX) Panama City, Florida

<b>Position</b>	<b>Account Executive</b>
<b>Station Ownership</b>	Lockwood Broadcasting, Inc.
<b>Reference #</b>	<i>Will be assigned when submission is completed</i>
<b>Type</b>	Television
<b>Full / Part</b>	Full Time - Regular
<b>Experience</b>	1+ Year
<b>Posted</b>	4/8/2022
<b>Closes</b>	5/8/2022
<b>Time Left</b>	30 Days
<b>DMA</b>	#153
<b>Found In</b>	Sales - Account Executive



### Account Executive

WPGX-TV FOX 28 has openings for experienced Account Executives to manage and grow transactional business as well focusing on prospecting and closing new business. We are looking for a self-starter with proficiency in cold calling and creating and delivering presentations.

Duties include but are not limited to:

- Develop and maintain direct relationships with agencies and clients while driving revenue to achieve monthly goals
  - Close new and incremental business
  - Understand and interpret business objectives and advertising strategies of clients in order to help them achieve those objectives through effective use of our product portfolio
  - Prepare, schedule and deliver sales presentations
- Qualifications/Requirements:

- Must be willing to work in Panama City, FL
- Proficient in the operation of a computer keyboard
- Proficient in Microsoft Products including but not limited to Outlook, PowerPoint, Word and Excel
- Good driving record
- One-three years of television sales experience is preferred



### Supplemental Information

<b>Salary Type</b>	
<b>Salary Range</b>	
<b>Starting Salary / Year</b>	
<b>Starting Salary / Hour</b>	
<b>Job Type</b>	Full Time - Regular
<b>Hours</b>	
<b>Workweek</b>	
<b>Scheduled on Holidays</b>	
<b>Start Date</b>	
<b>Probation Period</b>	
<b>Benefits</b>	
<b>Benefit Premium</b>	
<b>401K Plan</b>	
<b>Vacation</b>	
<b>Paid Sick Leave</b>	
<b>Phone Calls</b>	No
<b>Agent Phone Calls</b>	No
<b>Résumé</b>	Required
<b>Cover Letter</b>	Required
<b>References</b>	
<b>Salary History</b>	
<b>Tape / Reel</b>	
<b>Tape Format</b>	
<b>Tape Return</b>	
<b>Director's Track</b>	
<b>FAX Résumé</b>	No
<b>TVJobs.com E-Résumé</b>	
<b>Degree Required</b>	Preferred
<b>Contract Required</b>	



Bachelor's degree in advertising or marketing is preferred  
Skills and Abilities:

Strong communication skills  
Excellent negotiation and customer service skills  
Team player, who is flexible to changing needs to daily business  
Ability to work in a rapid-pace environment  
Lockwood Broadcast Group and WPGX-TV FOX 28 provides equal employment opportunities to all employees and applicants for employment and prohibits discrimination and harassment of any type without regard to race, color, religion, age, sex, national origin, disability status, genetics, protected veteran status, sexual orientation, gender identity or expression, or any other characteristic protected by federal, state or local laws. Pre-employment drug test is required along with a background screen as allowed by federal, state, and local laws and regulations.

Please send resumes to: GSM Shawna Greene  
SGreene@wpgxfox28.com

700 West 23rd Street C-28  
Panama City, FL. 32405

When responding to this job ad, please mention you saw it listed at TVJobs.com

© Broadcast Employment Services 1994-2022



All applicants are required to submit this application form.

[ [View other WPGX job listings](#) ]

- Contract Length
- Special Requirements
- Driver's License
- Insurance
- Good Driving Record
- Heavy Lifting
- Previous Applicants
- Local Apartment Rental
- Moving Expenses

- Union Position
- Union Contract Expires

- Confirmation Letter
- Rejection Letter
- Feedback

- Drug Screen
- Proof of Eligibility to work in U.S. Required

Equal Opportunity Employment	Yes
EOE Data Form	Yes

■ **Additional WPGX Information**

- Station Address
- Station Information
- Station Profile
- Station Website

April 8, 2022

Dear Sir or Madam,

WPGX requests your assistance in identifying and locating individuals who may be interested in the following job position(s) now available with our company:

Account Executive

WPGX is an equal opportunity employer and does not discriminate in the hiring, training or promotion of employees by reason of race, color, religion, sex, or national origin. We are engaged in a continuing effort to seek out prospective applicants for employment with our company. We earnestly solicit your assistance in obtaining employees and request that you refer prospective applicants to the address below.

Please refer all qualified applicants to us as they occur. For a complete list of job duties, please call. At this time, we anticipate an ongoing effort in the recruitment of these positions.

Sincerely,

*Tiffany Humphrey*

Tiffany Humphrey  
Corporate Business Manager

**Exhibit 4**

Position 2: Account Executive

Date Filled: 7/5/2023

<b>Recruitment Documentation Attached</b>	<b>Date</b>
TVJobs advertisements	8/4/2022; 9/7/2022; 10/5/2022; 11/3/2022; 12/7/2022; 1/6/2023; 2/2/2023; 3/3/2023; 4/4/2023; 5/5/2023; 6/5/2023
Employ Florida advertisements	8/4/2022; 9/7/2022; 10/5/2022; 11/3/2022; 12/7/2022; 1/6/2023; 2/2/2023; 3/3/2023; 4/4/2023; 5/5/2023; 6/5/2023
WPGX website advertisements	9/7/2022; 10/5/2022; 11/3/2022; 12/7/2022; 1/6/2023; 2/2/2023; 3/3/2023; 4/4/2023; 5/5/2023; 6/5/2023
Outreach letters*	8/4/2022

\* A sample outreach letter is attached. Licensee confirms that substantially similar letters were sent to each of the recruitment sources listed in the EEO Public File Report for the relevant period, attached hereto as Exhibit 2.

Where advertisements were disseminated multiple times, one example of the advertisement is provided herein. Copies of subsequent placements of the same material have been retained by WPGX and is available upon request.

# Job Listing Preview



Broadcast Employment Services

**FOX** WPGX (FOX) Panama City, Florida

**Position** Account Executive  
**Station Ownership** Lockwood Broadcasting, Inc.  
**Reference #** Will be assigned when submission is completed  
**Type** Television  
**Full / Part** Full Time - Regular  
**Experience** 1+ Year  
**Posted** 1/6/2023  
**Closes** 2/6/2023  
**Time Left** 31 Days  
**DMA** #153  
**Found In** Sales - Account Executive



## Account Executive

WPGX-TV FOX 28 has openings for experienced Account Executives to manage and grow transactional business as well focusing on prospecting and closing new business. We are looking for a self-starter with proficiency in cold calling and creating and delivering presentations.

Duties include but are not limited to:

Develop and maintain direct relationships with agencies and clients while driving revenue to achieve monthly goals

Close new and incremental business

Understand and interpret business objectives and advertising strategies of clients in order to help them achieve those objectives through effective use of our product portfolio

Prepare, schedule and deliver sales presentations  
 Qualifications/Requirements:

Must be willing to work in Panama City, FL  
 Proficient in the operation of a computer keyboard  
 Proficient in Microsoft Products including but not limited to Outlook, PowerPoint, Word and Excel  
 Good driving record  
 One-three years of television sales experience is



## Supplemental Information

**Salary Type**  
**Salary Range**  
**Starting Salary / Year**  
**Starting Salary / Hour**  
**Job Type** Full Time - Regular  
**Hours**  
**Workweek**  
**Scheduled on Holidays**  
**Start Date**  
**Probation Period**  
**Benefits**  
**Benefit Premium**  
**401K Plan**  
**Vacation**  
**Paid Sick Leave**  
**Phone Calls** No  
**Agent Phone Calls** No  
**Résumé** Required  
**Cover Letter** Required  
**References**  
**Salary History**  
**Tape / Reel**  
**Tape Format**  
**Tape Return**  
**Director's Track**  
**FAX Résumé** No  
**TVJobs.com E-Résumé**  
**Degree Required** Preferred  
**Contract Required**

preferred  
Bachelor's degree in advertising or marketing is preferred  
Skills and Abilities:

Strong communication skills  
Excellent negotiation and customer service skills  
Team player, who is flexible to changing needs to daily business  
Ability to work in a rapid-pace environment  
Lockwood Broadcast Group and WPGX-TV FOX 28 provides equal employment opportunities to all employees and applicants for employment and prohibits discrimination and harassment of any type without regard to race, color, religion, age, sex, national origin, disability status, genetics, protected veteran status, sexual orientation, gender identity or expression, or any other characteristic protected by federal, state or local laws. Pre-employment drug test is required along with a background screen as allowed by federal, state, and local laws and regulations.

Please send resumes to: GSM Shawna Greene  
SGreene@wpgxfox28.com

700 West 23rd Street C-28  
Panama City, FL 32405

---

When responding to this job ad, please mention you saw it listed at TVJobs.com

© Broadcast Employment Services 1994-2023

---

[ [View other WPGX job listings](#) ]

- Contract Length**
- Special Requirements**
- Driver's License**
- Insurance**
- Good Driving Record** Required
- Heavy Lifting**
- Previous Applicants**
- Local Apartment Rental**
- Moving Expenses**
- Union Position**
- Union Contract Expires**
- Confirmation Letter**
- Rejection Letter**
- Feedback**
- Drug Screen**
- Proof of Eligibility to work in U.S. Required**
- Equal Opportunity Employment** Yes
- EOE Data Form** Yes

---

■ **Additional WPGX Information**

- Station Address
- Station Information
- Station Profile
- Station Website

## Job Description

### Job Description

WPGX-TV FOX 28 has openings for experienced Account Executives to manage and grow transactional business as well focusing on prospecting and closing new business. We are looking for a self-starter with proficiency in cold calling and creating and delivering presentations. Duties include but are not limited to:

- Develop and maintain direct relationships with agencies and clients while driving revenue to achieve monthly goals
- Close new and incremental business
- Understand and interpret business objectives and advertising strategies of clients in order to help them achieve those objectives through effective use of our product portfolio
- Prepare, schedule and deliver sales presentations

#### Qualifications/Requirements:

- Must be willing to work in Panama City, FL
- Proficient in the operation of a computer keyboard
- Proficient in Microsoft Products including but not limited to Outlook, PowerPoint, Word and Excel
- **Good driving record**
- One-three years of television sales experience is preferred
- Bachelor's degree in advertising or marketing is preferred

#### Skills and Abilities:

- Strong communication skills
- Excellent negotiation and customer service skills
- Team player, who is flexible to changing needs to daily business
- Ability to work in a rapid-pace environment

Lockwood Broadcast Group and WPGX-TV FOX 28 provides equal employment opportunities to all employees and applicants for employment and prohibits discrimination and harassment of any type without regard to race, color, religion, age, sex, national origin, disability status, genetics, protected veteran status, sexual orientation, gender identity or expression, or any other characteristic protected by federal, state or local laws. **Pre-employment drug test is required along with a background screen as allowed by federal, state, and local laws and regulations.**

#### Employer Research

### Employer Research

Panama City TV LLC- WPGX Fox  
Is a Private Sector employer with 2 locations  
**Company Profile:**

## NEWS

**Account Executive**

~~WPGX-TV FOX 28 has openings for experienced Account Executives to manage and grow transactional business as well focusing on prospecting and closing new business. We are looking for a self-starter with proficiency in cold calling and creating and delivering presentations.~~

Duties include but are not limited to:

- Develop and maintain direct relationships with agencies and clients while driving revenue to achieve monthly goals
- Close new and incremental business
- Understand and interpret business objectives and advertising strategies of clients in order to help them achieve those objectives through effective use of our product portfolio
- Prepare, schedule and deliver sales presentations

Qualifications/Requirements:

- Must be willing to work in Panama City, FL
- Proficient in the operation of a computer keyboard
- Proficient in Microsoft Products including but not limited to Outlook, PowerPoint, Word and Excel
- Good driving record
- One-three years of television sales experience is preferred
- Bachelor's degree in advertising or marketing is preferred

Skills and Abilities:

- Strong communication skills
- Excellent negotiation and customer service skills
- Team player, who is flexible to changing needs to daily business
- Ability to work in a rapid-pace environment

Lockwood Broadcast Group and WPGX-TV FOX 28 provides equal employment opportunities to all employees and applicants for employment and prohibits discrimination and harassment of any type without regard to race, color, religion, age, sex, national origin, disability status, genetics, protected veteran status, sexual orientation, gender identity or expression, or any other characteristic protected by federal, state or local laws. Pre-employment drug test is required along with a background screen as allowed by federal, state, and local laws and regulations.

Please send resumes to: GSM Shawna Greene [SGreene@wpgxfox28.com](mailto:SGreene@wpgxfox28.com) (<mailto:SGreene@wpgxfox28.com>)

Posted 11/3/22 - Still active 1/6/23

1/6/23, 10:13 AM

Employ Florida - Job Details

## Job Summary

Position range in Panama City, FL Metropolitan Statistical Area

# \$30k - \$63k

Per year

## Account Executive (AE) Panama City TV LLC- WPGX Fox

Occupation: Advertising Sales Agents

Location: Panama City, FL - 32405 Positions available: 1

Job #: 11488812 Work At Home option: No

Updated: 11/3/2022 Expires: 12/31/2023

Source: Employ Florida Site: Employ Florida

## Job Requirements

---

HS

6



## Job Properties

---





**Exhibit 5**

Documents Concerning the Station's General Outreach Programs

[Attached]

## Script for EEO Spot WPGX

Are you interested in a rewarding television and radio career opportunities in the state of Florida. If you said yes, the log on to [FAB.org](http://FAB.org) and click on careers. There you will find the latest opportunities for broadcasting careers throughout the state from news anchors to videographers to opportunities in sales and marketing. The Florida Association of Broadcasters is there to help connect you to a rewarding career in television and radio. Visit their site today to find out more about the radio and television opportunities that are right for you.

# INVOICE



**WPGX-TV**  
**700 W 23rd St #28**  
**Panama City, FL 32405**  
**Main: (804) 672-6565**  
**Billing: (804) 672-6565**

Property	WPGX		
Invoice #	122020-15	Order #	122020
Invoice Date	10/31/21	Alt Order #	
Invoice Month	October 2021	Deal #	
Invoice Period	09/27/21 - 10/31/21	Flight Dates	08/23/20 - 12/31/24
Advertiser	WPGX-Public Service		
Product	Compliance - EEO		
Estimate #	Compliance - EEO		
Account Executive	WPGX House		
Sales Office	Panama City Local		
Sales Region	Local		
Agency Code			
Advertiser Code			
Billing Calendar	Broadcast		
Billing Type	Cash		
Special Handling	Do Not Mail		
Agency Ref			
Advertiser Ref			
Product 1			
Product 2			

Billing Address:

**WPGX-Public Service**  
**Attention: Accounts Payable**  
**XXXX**  
**XXXX, XX XXXXX**

Send Payment To:

**WPGX-TV**  
**3914 Wistar Road**  
**Richmond, VA 23228**

Line	Start Date	End Date	Description	Start/End Time	MTWTFSS	Length	Spots/ Week	Rate	Type
1	08/23/20	12/31/24		5a-5x	MTWTFSS	:30	2	\$0.00	NM
Weeks: <u>Start Date</u> <u>End Date</u> <u>MTWTFSS</u> <u>Spots/Week</u> <u>Rate</u> 09/27/21 10/03/21 MTWTFSS 2 \$0.00									
Spots: # <u>Ch</u> <u>Day</u> <u>Air Date</u> <u>Air Time</u> <u>Description</u> <u>Start/End Time</u> <u>Length</u> <u>Ad-ID</u> <u>Rate</u> <u>Type</u> 118 WPGX M 09/27/21 4:29 AM 5a-5x :30 Panama City EEO :30 \$0.00 NM 117 WPGX Sa 10/02/21 2:09 AM 5a-5x :30 Panama City EEO :30 \$0.00 NM									
Weeks: <u>Start Date</u> <u>End Date</u> <u>MTWTFSS</u> <u>Spots/Week</u> <u>Rate</u> 10/04/21 10/10/21 MTWTFSS 2 \$0.00									
Spots: # <u>Ch</u> <u>Day</u> <u>Air Date</u> <u>Air Time</u> <u>Description</u> <u>Start/End Time</u> <u>Length</u> <u>Ad-ID</u> <u>Rate</u> <u>Type</u> 120 WPGX M 10/04/21 10:59 AM 5a-5x :30 Panama City EEO :30 \$0.00 NM 119 WPGX Tu 10/05/21 1:11 AM 5a-5x :30 Panama City EEO :30 \$0.00 NM									
Weeks: <u>Start Date</u> <u>End Date</u> <u>MTWTFSS</u> <u>Spots/Week</u> <u>Rate</u> 10/11/21 10/17/21 MTWTFSS 2 \$0.00									
Spots: # <u>Ch</u> <u>Day</u> <u>Air Date</u> <u>Air Time</u> <u>Description</u> <u>Start/End Time</u> <u>Length</u> <u>Ad-ID</u> <u>Rate</u> <u>Type</u> 121 WPGX M 10/11/21 12:11 PM 5a-5x :30 Panama City EEO :30 \$0.00 NM 122 WPGX Tu 10/12/21 3:29 AM 5a-5x :30 Panama City EEO :30 \$0.00 NM									
Weeks: <u>Start Date</u> <u>End Date</u> <u>MTWTFSS</u> <u>Spots/Week</u> <u>Rate</u> 10/18/21 10/24/21 MTWTFSS 2 \$0.00									
Spots: # <u>Ch</u> <u>Day</u> <u>Air Date</u> <u>Air Time</u> <u>Description</u> <u>Start/End Time</u> <u>Length</u> <u>Ad-ID</u> <u>Rate</u> <u>Type</u> 124 WPGX F 10/22/21 6:52 PM 5a-5x :30 Panama City EEO :30 \$0.00 NM 123 WPGX Sa 10/23/21 1:50 AM 5a-5x :30 Panama City EEO :30 \$0.00 NM									
Weeks: <u>Start Date</u> <u>End Date</u> <u>MTWTFSS</u> <u>Spots/Week</u> <u>Rate</u> 10/25/21 10/31/21 MTWTFSS 2 \$0.00									
Spots: # <u>Ch</u> <u>Day</u> <u>Air Date</u> <u>Air Time</u> <u>Description</u> <u>Start/End Time</u> <u>Length</u> <u>Ad-ID</u> <u>Rate</u> <u>Type</u> 125 WPGX M 10/25/21 2:59 PM 5a-5x :30 Panama City EEO :30 \$0.00 NM 126 WPGX Tu 10/26/21 8:45 AM 5a-5x :30 Panama City EEO :30 \$0.00 NM									

**Total Spots 10**

## Payment Terms 30 Days

**Net Total \$0.00**

**Invoice Balance as of 04/18/24 12:39:55 PM ET \$0.00**

We warrant that the actual broadcast information shown on this invoice was taken from the program log. Lockwood Broadcast Group does not discriminate in its advertising contracts, and it will not accept advertising intended to discriminate on the basis of race or ethnicity. Advertiser hereto affirms that nothing in this Agreement is intended to discriminate on the basis of race or ethnicity.

# INVOICE



**WPGX-TV**  
**700 W 23rd St #28**  
**Panama City, FL 32405**  
**Main: (804) 672-6565**  
**Billing: (804) 672-6565**

Property	WPGX		
Invoice #	122020-16	Order #	122020
Invoice Date	11/28/21	Alt Order #	
Invoice Month	November 2021	Deal #	
Invoice Period	11/01/21 - 11/28/21	Flight Dates	08/23/20 - 12/31/24
Advertiser	WPGX-Public Service		
Product	Compliance - EEO		
Estimate #	Compliance - EEO		
Account Executive	WPGX House		
Sales Office	Panama City Local		
Sales Region	Local		
Agency Code			
Advertiser Code			
Billing Calendar	Broadcast		
Billing Type	Cash		
Special Handling	Do Not Mail		
Agency Ref			
Advertiser Ref			
Product 1			
Product 2			

Billing Address:

**WPGX-Public Service**  
**Attention: Accounts Payable**  
**XXXX**  
**XXXX, XX XXXXX**

Send Payment To:

**WPGX-TV**  
**3914 Wistar Road**  
**Richmond, VA 23228**

Line	Start Date	End Date	Description	Start/End Time	MTWTFSS	Length	Spots/ Week	Rate	Type
1	08/23/20	12/31/24		5a-5x	MTWTFSS	:30	2	\$0.00	NM
Weeks: <u>Start Date</u> <u>End Date</u> <u>MTWTFSS</u> <u>Spots/Week</u> <u>Rate</u> 11/01/21 11/07/21 MTWTFSS 2 \$0.00									
Spots: # <u>Ch</u> <u>Day</u> <u>Air Date</u> <u>Air Time</u> <u>Description</u> <u>Start/End Time</u> <u>Length</u> <u>Ad-ID</u> <u>Rate</u> <u>Type</u> 128 WPGX Tu 11/02/21 4:58 PM 5a-5x :30 Panama City EEO :30 \$0.00 NM 127 WPGX W 11/03/21 11:53 AM 5a-5x :30 Panama City EEO :30 \$0.00 NM									
Weeks: <u>Start Date</u> <u>End Date</u> <u>MTWTFSS</u> <u>Spots/Week</u> <u>Rate</u> 11/08/21 11/14/21 MTWTFSS 2 \$0.00									
Spots: # <u>Ch</u> <u>Day</u> <u>Air Date</u> <u>Air Time</u> <u>Description</u> <u>Start/End Time</u> <u>Length</u> <u>Ad-ID</u> <u>Rate</u> <u>Type</u> 130 WPGX M 11/08/21 11:26 PM 5a-5x :30 Panama City EEO :30 \$0.00 NM 129 WPGX F 11/12/21 12:51 AM 5a-5x :30 Panama City EEO :30 \$0.00 NM									
Weeks: <u>Start Date</u> <u>End Date</u> <u>MTWTFSS</u> <u>Spots/Week</u> <u>Rate</u> 11/15/21 11/21/21 MTWTFSS 2 \$0.00									
Spots: # <u>Ch</u> <u>Day</u> <u>Air Date</u> <u>Air Time</u> <u>Description</u> <u>Start/End Time</u> <u>Length</u> <u>Ad-ID</u> <u>Rate</u> <u>Type</u> 131 WPGX Tu 11/16/21 2:12 AM 5a-5x :30 Panama City EEO :30 \$0.00 NM 132 WPGX Sa 11/20/21 3:59 AM 5a-5x :30 Panama City EEO :30 \$0.00 NM									
Weeks: <u>Start Date</u> <u>End Date</u> <u>MTWTFSS</u> <u>Spots/Week</u> <u>Rate</u> 11/22/21 11/28/21 MTWTFSS 2 \$0.00									
Spots: # <u>Ch</u> <u>Day</u> <u>Air Date</u> <u>Air Time</u> <u>Description</u> <u>Start/End Time</u> <u>Length</u> <u>Ad-ID</u> <u>Rate</u> <u>Type</u> 134 WPGX M 11/22/21 2:09 AM 5a-5x :30 Panama City EEO :30 \$0.00 NM 133 WPGX Tu 11/23/21 1:23 AM 5a-5x :30 Panama City EEO :30 \$0.00 NM									

**Total Spots 8**

## Payment Terms 30 Days

<u>Net Total</u>	<b>\$0.00</b>
<u>Invoice Balance as of 04/18/24 12:40:10 PM ET</u>	<b>\$0.00</b>

We warrant that the actual broadcast information shown on this invoice was taken from the program log. Lockwood Broadcast Group does not discriminate in its advertising contracts, and it will not accept advertising intended to discriminate on the basis of race or ethnicity. Advertiser hereto affirms that nothing in this Agreement is intended to discriminate on the basis of race or ethnicity.

# INVOICE



**WPGX-TV**  
**700 W 23rd St #28**  
**Panama City, FL 32405**  
**Main: (804) 672-6565**  
**Billing: (804) 672-6565**

Property	WPGX		
Invoice #	122020-17	Order #	122020
Invoice Date	12/26/21	Alt Order #	
Invoice Month	December 2021	Deal #	
Invoice Period	11/29/21 - 12/26/21	Flight Dates	08/23/20 - 12/31/24
Advertiser	WPGX-Public Service		
Product	Compliance - EEO		
Estimate #	Compliance - EEO		
Account Executive	WPGX House		
Sales Office	Panama City Local		
Sales Region	Local		
Agency Code			
Advertiser Code			
Billing Calendar	Broadcast		
Billing Type	Cash		
Special Handling	Do Not Mail		
Agency Ref			
Advertiser Ref			
Product 1			
Product 2			

Billing Address:

**WPGX-Public Service**  
**Attention: Accounts Payable**  
**XXXX**  
**XXXX, XX XXXXX**

Send Payment To:

**WPGX-TV**  
**3914 Wistar Road**  
**Richmond, VA 23228**

Line	Start Date	End Date	Description	Start/End Time	MTWTFSS	Length	Spots/ Week	Rate	Type
1	08/23/20	12/31/24		5a-5x	MTWTFSS	:30	2	\$0.00	NM
Weeks: <u>Start Date</u> <u>End Date</u> <u>MTWTFSS</u> <u>Spots/Week</u> <u>Rate</u> 11/29/21 12/05/21 MTWTFSS 2 \$0.00									
Spots: # <u>Ch</u> <u>Day</u> <u>Air Date</u> <u>Air Time</u> <u>Description</u> <u>Start/End Time</u> <u>Length</u> <u>Ad-ID</u> <u>Rate</u> <u>Type</u> 135 WPGX M 11/29/21 8:45 AM 5a-5x :30 Panama City EEO :30 \$0.00 NM 136 WPGX Th 12/02/21 1:15 AM 5a-5x :30 Panama City EEO :30 \$0.00 NM									
Weeks: <u>Start Date</u> <u>End Date</u> <u>MTWTFSS</u> <u>Spots/Week</u> <u>Rate</u> 12/06/21 12/12/21 MTWTFSS 2 \$0.00									
Spots: # <u>Ch</u> <u>Day</u> <u>Air Date</u> <u>Air Time</u> <u>Description</u> <u>Start/End Time</u> <u>Length</u> <u>Ad-ID</u> <u>Rate</u> <u>Type</u> 138 WPGX M 12/06/21 12:44 AM 5a-5x :30 Panama City EEO :30 \$0.00 NM 137 WPGX Sa 12/11/21 5a-5x :00 <del>\$0.00</del> NM Unresolved Oversold									
Weeks: <u>Start Date</u> <u>End Date</u> <u>MTWTFSS</u> <u>Spots/Week</u> <u>Rate</u> 12/13/21 12/19/21 MTWTFSS 2 \$0.00									
Spots: # <u>Ch</u> <u>Day</u> <u>Air Date</u> <u>Air Time</u> <u>Description</u> <u>Start/End Time</u> <u>Length</u> <u>Ad-ID</u> <u>Rate</u> <u>Type</u> 139 WPGX M 12/13/21 2:20 AM 5a-5x :30 Panama City EEO :30 \$0.00 NM 140 WPGX F 12/17/21 1:22 AM 5a-5x :30 Panama City EEO :30 \$0.00 NM									
Weeks: <u>Start Date</u> <u>End Date</u> <u>MTWTFSS</u> <u>Spots/Week</u> <u>Rate</u> 12/20/21 12/26/21 MTWTFSS 2 \$0.00									
Spots: # <u>Ch</u> <u>Day</u> <u>Air Date</u> <u>Air Time</u> <u>Description</u> <u>Start/End Time</u> <u>Length</u> <u>Ad-ID</u> <u>Rate</u> <u>Type</u> 141 WPGX M 12/20/21 2:09 AM 5a-5x :30 Panama City EEO :30 \$0.00 NM 142 WPGX F 12/24/21 12:56 AM 5a-5x :30 Panama City EEO :30 \$0.00 NM									

**Total Spots 7**

## Payment Terms 30 Days

**Net Total \$0.00**

**Invoice Balance as of 04/18/24 12:40:33 PM ET \$0.00**

We warrant that the actual broadcast information shown on this invoice was taken from the program log. Lockwood Broadcast Group does not discriminate in its advertising contracts, and it will not accept advertising intended to discriminate on the basis of race or ethnicity. Advertiser hereto affirms that nothing in this Agreement is intended to discriminate on the basis of race or ethnicity.

# INVOICE



**WPGX-TV**  
**700 W 23rd St #28**  
**Panama City, FL 32405**  
**Main: (804) 672-6565**  
**Billing: (804) 672-6565**

Property	WPGX		
Invoice #	122020-18	Order #	122020
Invoice Date	01/30/22	Alt Order #	
Invoice Month	January 2022	Deal #	
Invoice Period	12/27/21 - 01/30/22	Flight Dates	08/23/20 - 12/31/24
Advertiser	WPGX-Public Service		
Product	Compliance - EEO		
Estimate #	Compliance - EEO		
Account Executive	WPGX House		
Sales Office	Panama City Local		
Sales Region	Local		
Agency Code			
Advertiser Code			
Billing Calendar	Broadcast		
Billing Type	Cash		
Special Handling	Do Not Mail		
Agency Ref			
Advertiser Ref			
Product 1			
Product 2			

Billing Address:

**WPGX-Public Service**  
**Attention: Accounts Payable**  
**XXXX**  
**XXXX, XX XXXXX**

Send Payment To:

**WPGX-TV**  
**3914 Wistar Road**  
**Richmond, VA 23228**

Line	Start Date	End Date	Description	Start/End Time	MTWTFSS	Length	Spots/ Week	Rate	Type
1	08/23/20	12/31/24		5a-5x	MTWTFSS	:30	2	\$0.00	NM
Weeks: <u>Start Date</u> <u>End Date</u> <u>MTWTFSS</u> <u>Spots/Week</u> <u>Rate</u> 12/27/21 01/02/22 MTWTF-- 2 \$0.00									
Spots: # <u>Ch</u> <u>Day</u> <u>Air Date</u> <u>Air Time</u> <u>Description</u> <u>Start/End Time</u> <u>Length</u> <u>Ad-ID</u> <u>Rate</u> <u>Type</u> 144 WPGX M 12/27/21 5:10 PM 5a-5x :30 Panama City EEO :30 \$0.00 NM 143 WPGX W 12/29/21 10:58 AM 5a-5x :30 Panama City EEO :30 \$0.00 NM									
Weeks: <u>Start Date</u> <u>End Date</u> <u>MTWTFSS</u> <u>Spots/Week</u> <u>Rate</u> 01/03/22 01/09/22 MTWTFSS 2 \$0.00									
Spots: # <u>Ch</u> <u>Day</u> <u>Air Date</u> <u>Air Time</u> <u>Description</u> <u>Start/End Time</u> <u>Length</u> <u>Ad-ID</u> <u>Rate</u> <u>Type</u> 146 WPGX Th 01/06/22 6:45 PM 5a-5x :30 Panama City EEO :30 \$0.00 NM 145 WPGX Su 01/09/22 1:59 AM 5a-5x :30 Panama City EEO :30 \$0.00 NM									
Weeks: <u>Start Date</u> <u>End Date</u> <u>MTWTFSS</u> <u>Spots/Week</u> <u>Rate</u> 01/10/22 01/16/22 MTWTFSS 2 \$0.00									
Spots: # <u>Ch</u> <u>Day</u> <u>Air Date</u> <u>Air Time</u> <u>Description</u> <u>Start/End Time</u> <u>Length</u> <u>Ad-ID</u> <u>Rate</u> <u>Type</u> 148 WPGX Th 01/13/22 1:32 PM 5a-5x :30 Panama City EEO :30 \$0.00 NM 147 WPGX Su 01/16/22 6:29 AM 5a-5x :30 Panama City EEO :30 \$0.00 NM									
Weeks: <u>Start Date</u> <u>End Date</u> <u>MTWTFSS</u> <u>Spots/Week</u> <u>Rate</u> 01/17/22 01/23/22 MTWTFSS 2 \$0.00									
Spots: # <u>Ch</u> <u>Day</u> <u>Air Date</u> <u>Air Time</u> <u>Description</u> <u>Start/End Time</u> <u>Length</u> <u>Ad-ID</u> <u>Rate</u> <u>Type</u> 150 WPGX Th 01/20/22 12:27 PM 5a-5x :30 Panama City EEO :30 \$0.00 NM 149 WPGX Su 01/23/22 11:29 PM 5a-5x :30 Panama City EEO :30 \$0.00 NM									
Weeks: <u>Start Date</u> <u>End Date</u> <u>MTWTFSS</u> <u>Spots/Week</u> <u>Rate</u> 01/24/22 01/30/22 MTWTFSS 2 \$0.00									
Spots: # <u>Ch</u> <u>Day</u> <u>Air Date</u> <u>Air Time</u> <u>Description</u> <u>Start/End Time</u> <u>Length</u> <u>Ad-ID</u> <u>Rate</u> <u>Type</u> 151 WPGX W 01/26/22 1:22 AM 5a-5x :30 Panama City EEO :30 \$0.00 NM 152 WPGX Su 01/30/22 7:29 AM 5a-5x :30 Panama City EEO :30 \$0.00 NM									

**Total Spots 10**

## Payment Terms 30 Days

**Net Total \$0.00**

**Invoice Balance as of 04/18/24 12:47:25 PM ET \$0.00**

We warrant that the actual broadcast information shown on this invoice was taken from the program log. Lockwood Broadcast Group does not discriminate in its advertising contracts, and it will not accept advertising intended to discriminate on the basis of race or ethnicity. Advertiser hereto affirms that nothing in this Agreement is intended to discriminate on the basis of race or ethnicity.

# INVOICE



**WPGX-TV**  
**700 W 23rd St #28**  
**Panama City, FL 32405**  
**Main: (804) 672-6565**  
**Billing: (804) 672-6565**

Property	WPGX		
Invoice #	122020-19	Order #	122020
Invoice Date	02/27/22	Alt Order #	
Invoice Month	February 2022	Deal #	
Invoice Period	01/31/22 - 02/27/22	Flight Dates	08/23/20 - 12/31/24
Advertiser	WPGX-Public Service		
Product	Compliance - EEO		
Estimate #	Compliance - EEO		
Account Executive	WPGX House		
Sales Office	Panama City Local		
Sales Region	Local		
Agency Code			
Advertiser Code			
Billing Calendar	Broadcast		
Billing Type	Cash		
Special Handling	Do Not Mail		
Agency Ref			
Advertiser Ref			
Product 1			
Product 2			

Billing Address:

**WPGX-Public Service**  
**Attention: Accounts Payable**  
**XXXX**  
**XXXX, XX XXXXX**

Send Payment To:

**WPGX-TV**  
**3914 Wistar Road**  
**Richmond, VA 23228**

Line	Start Date	End Date	Description	Start/End Time	MTWTFSS	Length	Spots/ Week	Rate	Type
1	08/23/20	12/31/24		5a-5x	MTWTFSS	:30	2	\$0.00	NM
Weeks: <u>Start Date</u> <u>End Date</u> <u>MTWTFSS</u> <u>Spots/Week</u> <u>Rate</u> 01/31/22 02/06/22 MTWTFSS 2 \$0.00									
Spots: # <u>Ch</u> <u>Day</u> <u>Air Date</u> <u>Air Time</u> <u>Description</u> <u>Start/End Time</u> <u>Length</u> <u>Ad-ID</u> <u>Rate</u> <u>Type</u> 154 WPGX W 02/02/22 10:29 PM 5a-5x :30 Panama City EEO :30 \$0.00 NM 153 WPGX Th 02/03/22 1:20 AM 5a-5x :30 Panama City EEO :30 \$0.00 NM									
Weeks: <u>Start Date</u> <u>End Date</u> <u>MTWTFSS</u> <u>Spots/Week</u> <u>Rate</u> 02/07/22 02/13/22 MTWTFSS 2 \$0.00									
Spots: # <u>Ch</u> <u>Day</u> <u>Air Date</u> <u>Air Time</u> <u>Description</u> <u>Start/End Time</u> <u>Length</u> <u>Ad-ID</u> <u>Rate</u> <u>Type</u> 155 WPGX M 02/07/22 3:43 PM 5a-5x :30 Panama City EEO :30 \$0.00 NM 156 WPGX Th 02/10/22 2:42 PM 5a-5x :30 Panama City EEO :30 \$0.00 NM									
Weeks: <u>Start Date</u> <u>End Date</u> <u>MTWTFSS</u> <u>Spots/Week</u> <u>Rate</u> 02/14/22 02/20/22 MTWTFSS 2 \$0.00									
Spots: # <u>Ch</u> <u>Day</u> <u>Air Date</u> <u>Air Time</u> <u>Description</u> <u>Start/End Time</u> <u>Length</u> <u>Ad-ID</u> <u>Rate</u> <u>Type</u> 158 WPGX M 02/14/22 12:50 PM 5a-5x :30 Panama City EEO :30 \$0.00 NM 157 WPGX Tu 02/15/22 12:27 PM 5a-5x :30 Panama City EEO :30 \$0.00 NM									
Weeks: <u>Start Date</u> <u>End Date</u> <u>MTWTFSS</u> <u>Spots/Week</u> <u>Rate</u> 02/21/22 02/27/22 MTWTFSS 2 \$0.00									
Spots: # <u>Ch</u> <u>Day</u> <u>Air Date</u> <u>Air Time</u> <u>Description</u> <u>Start/End Time</u> <u>Length</u> <u>Ad-ID</u> <u>Rate</u> <u>Type</u> 159 WPGX M 02/21/22 5:18 PM 5a-5x :30 Panama City EEO :30 \$0.00 NM 160 WPGX Tu 02/22/22 4:59 AM 5a-5x :30 Panama City EEO :30 \$0.00 NM									

**Total Spots 8**

## Payment Terms 30 Days

Net Total **\$0.00**

Invoice Balance as of 04/18/24 12:41:41 PM ET **\$0.00**

We warrant that the actual broadcast information shown on this invoice was taken from the program log. Lockwood Broadcast Group does not discriminate in its advertising contracts, and it will not accept advertising intended to discriminate on the basis of race or ethnicity. Advertiser hereto affirms that nothing in this Agreement is intended to discriminate on the basis of race or ethnicity.

# INVOICE



**WPGX-TV**  
**700 W 23rd St #28**  
**Panama City, FL 32405**  
**Main: (804) 672-6565**  
**Billing: (804) 672-6565**

Property	WPGX		
Invoice #	122020-20	Order #	122020
Invoice Date	03/27/22	Alt Order #	
Invoice Month	March 2022	Deal #	
Invoice Period	02/28/22 - 03/27/22	Flight Dates	08/23/20 - 12/31/24
Advertiser	WPGX-Public Service		
Product	Compliance - EEO		
Estimate #	Compliance - EEO		
Account Executive	WPGX House		
Sales Office	Panama City Local		
Sales Region	Local		
Agency Code			
Advertiser Code			
Billing Calendar	Broadcast		
Billing Type	Cash		
Special Handling	Do Not Mail		
Agency Ref			
Advertiser Ref			
Product 1			
Product 2			

Billing Address:

**WPGX-Public Service**  
**Attention: Accounts Payable**  
**XXXX**  
**XXXX, XX XXXXX**

Send Payment To:

**WPGX-TV**  
**3914 Wistar Road**  
**Richmond, VA 23228**

Line	Start Date	End Date	Description	Start/End Time	MTWTFSS	Length	Spots/ Week	Rate	Type
1	08/23/20	12/31/24		5a-5x	MTWTFSS	:30	2	\$0.00	NM
Weeks: <u>Start Date</u> <u>End Date</u> <u>MTWTFSS</u> <u>Spots/Week</u> <u>Rate</u> 02/28/22 03/06/22 MTWTFSS 2 \$0.00									
Spots: # <u>Ch</u> <u>Day</u> <u>Air Date</u> <u>Air Time</u> <u>Description</u> <u>Start/End Time</u> <u>Length</u> <u>Ad-ID</u> <u>Rate</u> <u>Type</u> 161 WPGX M 02/28/22 9:26 PM 5a-5x :30 Panama City EEO :30 \$0.00 NM 162 WPGX Th 03/03/22 10:57 PM 5a-5x :30 Panama City EEO :30 \$0.00 NM									
Weeks: <u>Start Date</u> <u>End Date</u> <u>MTWTFSS</u> <u>Spots/Week</u> <u>Rate</u> 03/07/22 03/13/22 MTWTFSS 2 \$0.00									
Spots: # <u>Ch</u> <u>Day</u> <u>Air Date</u> <u>Air Time</u> <u>Description</u> <u>Start/End Time</u> <u>Length</u> <u>Ad-ID</u> <u>Rate</u> <u>Type</u> 163 WPGX M 03/07/22 11:59 PM 5a-5x :30 Panama City EEO :30 \$0.00 NM 164 WPGX Tu 03/08/22 2:26 AM 5a-5x :30 Panama City EEO :30 \$0.00 NM									
Weeks: <u>Start Date</u> <u>End Date</u> <u>MTWTFSS</u> <u>Spots/Week</u> <u>Rate</u> 03/14/22 03/20/22 MTWTFSS 2 \$0.00									
Spots: # <u>Ch</u> <u>Day</u> <u>Air Date</u> <u>Air Time</u> <u>Description</u> <u>Start/End Time</u> <u>Length</u> <u>Ad-ID</u> <u>Rate</u> <u>Type</u> 166 WPGX M 03/14/22 5:54 PM 5a-5x :30 Panama City EEO :30 \$0.00 NM 165 WPGX Tu 03/15/22 1:55 AM 5a-5x :30 Panama City EEO :30 \$0.00 NM									
Weeks: <u>Start Date</u> <u>End Date</u> <u>MTWTFSS</u> <u>Spots/Week</u> <u>Rate</u> 03/21/22 03/27/22 MTWTFSS 2 \$0.00									
Spots: # <u>Ch</u> <u>Day</u> <u>Air Date</u> <u>Air Time</u> <u>Description</u> <u>Start/End Time</u> <u>Length</u> <u>Ad-ID</u> <u>Rate</u> <u>Type</u> 167 WPGX M 03/21/22 3:29 AM 5a-5x :30 Panama City EEO :30 \$0.00 NM 168 WPGX Tu 03/22/22 2:08 AM 5a-5x :30 Panama City EEO :30 \$0.00 NM									

**Total Spots 8**

## Payment Terms 30 Days

<u>Net Total</u>	<b>\$0.00</b>
<u>Invoice Balance as of 04/18/24 12:41:58 PM ET</u>	<b>\$0.00</b>

We warrant that the actual broadcast information shown on this invoice was taken from the program log. Lockwood Broadcast Group does not discriminate in its advertising contracts, and it will not accept advertising intended to discriminate on the basis of race or ethnicity. Advertiser hereto affirms that nothing in this Agreement is intended to discriminate on the basis of race or ethnicity.



# INVOICE



**WPGX-TV**  
**700 W 23rd St #28**  
**Panama City, FL 32405**  
**Main: (804) 672-6565**  
**Billing: (804) 672-6565**

Property	WPGX		
Invoice #	122020-21	Order #	122020
Invoice Date	04/24/22	Alt Order #	
Invoice Month	April 2022	Deal #	
Invoice Period	03/28/22 - 04/24/22	Flight Dates	08/23/20 - 12/31/24
Advertiser	WPGX-Public Service		
Product	Compliance - EEO		
Estimate #	Compliance - EEO		
Account Executive	WPGX House		
Sales Office	Panama City Local		
Sales Region	Local		
Agency Code			
Advertiser Code			
Billing Calendar	Broadcast		
Billing Type	Cash		
Special Handling	Do Not Mail		
Agency Ref			
Advertiser Ref			
Product 1			
Product 2			

Billing Address:

**WPGX-Public Service**  
**Attention: Accounts Payable**  
**XXXX**  
**XXXX, XX XXXXX**

Send Payment To:

**WPGX-TV**  
**3914 Wistar Road**  
**Richmond, VA 23228**

Line	Start Date	End Date	Description	Start/End Time	MTWTFSS	Length	Spots/ Week	Rate	Type
1	08/23/20	12/31/24		5a-5x	MTWTFSS	:30	2	\$0.00	NM
Weeks: <u>Start Date</u> <u>End Date</u> <u>MTWTFSS</u> <u>Spots/Week</u> <u>Rate</u> 03/28/22 04/03/22 MTWTFSS 2 \$0.00									
Spots: # <u>Ch</u> <u>Day</u> <u>Air Date</u> <u>Air Time</u> <u>Description</u> <u>Start/End Time</u> <u>Length</u> <u>Ad-ID</u> <u>Rate</u> <u>Type</u> 169 WPGX M 03/28/22 4:59 AM 5a-5x :30 Panama City EEO :30 \$0.00 NM 170 WPGX Tu 03/29/22 8:15 AM 5a-5x :30 Panama City EEO :30 \$0.00 NM									
Weeks: <u>Start Date</u> <u>End Date</u> <u>MTWTFSS</u> <u>Spots/Week</u> <u>Rate</u> 04/04/22 04/10/22 MTWTFSS 2 \$0.00									
Spots: # <u>Ch</u> <u>Day</u> <u>Air Date</u> <u>Air Time</u> <u>Description</u> <u>Start/End Time</u> <u>Length</u> <u>Ad-ID</u> <u>Rate</u> <u>Type</u> 172 WPGX M 04/04/22 11:23 PM 5a-5x :30 Panama City EEO :30 \$0.00 NM 171 WPGX F 04/08/22 10:54 AM 5a-5x :30 Panama City EEO :30 \$0.00 NM									
Weeks: <u>Start Date</u> <u>End Date</u> <u>MTWTFSS</u> <u>Spots/Week</u> <u>Rate</u> 04/11/22 04/17/22 MTWTFSS 2 \$0.00									
Spots: # <u>Ch</u> <u>Day</u> <u>Air Date</u> <u>Air Time</u> <u>Description</u> <u>Start/End Time</u> <u>Length</u> <u>Ad-ID</u> <u>Rate</u> <u>Type</u> 173 WPGX M 04/11/22 1:20 PM 5a-5x :30 Panama City EEO :30 \$0.00 NM 174 WPGX Sa 04/16/22 6:59 AM 5a-5x :30 Panama City EEO :30 \$0.00 NM									
Weeks: <u>Start Date</u> <u>End Date</u> <u>MTWTFSS</u> <u>Spots/Week</u> <u>Rate</u> 04/18/22 04/24/22 MTWTFSS 2 \$0.00									
Spots: # <u>Ch</u> <u>Day</u> <u>Air Date</u> <u>Air Time</u> <u>Description</u> <u>Start/End Time</u> <u>Length</u> <u>Ad-ID</u> <u>Rate</u> <u>Type</u> 176 WPGX M 04/18/22 2:09 AM 5a-5x :30 Panama City EEO :30 \$0.00 NM 175 WPGX Tu 04/19/22 1:22 AM 5a-5x :30 Panama City EEO :30 \$0.00 NM									

**Total Spots 8**

## Payment Terms 30 Days

<u>Net Total</u>	<b>\$0.00</b>
<u>Invoice Balance as of 04/18/24 12:42:16 PM ET</u>	<b>\$0.00</b>

We warrant that the actual broadcast information shown on this invoice was taken from the program log. Lockwood Broadcast Group does not discriminate in its advertising contracts, and it will not accept advertising intended to discriminate on the basis of race or ethnicity. Advertiser hereto affirms that nothing in this Agreement is intended to discriminate on the basis of race or ethnicity.

# INVOICE



**WPGX-TV**  
**700 W 23rd St #28**  
**Panama City, FL 32405**  
**Main: (804) 672-6565**  
**Billing: (804) 672-6565**

Property	WPGX		
Invoice #	122020-22	Order #	122020
Invoice Date	05/29/22	Alt Order #	
Invoice Month	May 2022	Deal #	
Invoice Period	04/25/22 - 05/29/22	Flight Dates	08/23/20 - 12/31/24
Advertiser	WPGX-Public Service		
Product	Compliance - EEO		
Estimate #	Compliance - EEO		
Account Executive	WPGX House		
Sales Office	Panama City Local		
Sales Region	Local		
Agency Code			
Advertiser Code			
Billing Calendar	Broadcast		
Billing Type	Cash		
Special Handling	Do Not Mail		
Agency Ref			
Advertiser Ref			
Product 1			
Product 2			

Billing Address:

**WPGX-Public Service**  
**Attention: Accounts Payable**  
**XXXX**  
**XXXX, XX XXXXX**

Send Payment To:

**WPGX-TV**  
**3914 Wistar Road**  
**Richmond, VA 23228**

Line	Start Date	End Date	Description	Start/End Time	MTWTFSS	Length	Spots/ Week	Rate	Type
1	08/23/20	12/31/24		5a-5x	MTWTFSS	:30	2	\$0.00	NM
Weeks: <u>Start Date</u> <u>End Date</u> <u>MTWTFSS</u> <u>Spots/Week</u> <u>Rate</u> 04/25/22 05/01/22 MTWTFSS 2 \$0.00									
Spots: # <u>Ch</u> <u>Day</u> <u>Air Date</u> <u>Air Time</u> <u>Description</u> <u>Start/End Time</u> <u>Length</u> <u>Ad-ID</u> <u>Rate</u> <u>Type</u> 178 WPGX M 04/25/22 4:29 AM 5a-5x :30 Panama City EEO :30 \$0.00 NM 177 WPGX Tu 04/26/22 2:59 AM 5a-5x :30 Panama City EEO :30 \$0.00 NM									
Weeks: <u>Start Date</u> <u>End Date</u> <u>MTWTFSS</u> <u>Spots/Week</u> <u>Rate</u> 05/02/22 05/08/22 MTWTFSS 2 \$0.00									
Spots: # <u>Ch</u> <u>Day</u> <u>Air Date</u> <u>Air Time</u> <u>Description</u> <u>Start/End Time</u> <u>Length</u> <u>Ad-ID</u> <u>Rate</u> <u>Type</u> 180 WPGX M 05/02/22 6:49 PM 5a-5x :30 Panama City EEO :30 \$0.00 NM 179 WPGX Tu 05/03/22 2:28 AM 5a-5x :30 Panama City EEO :30 \$0.00 NM									
Weeks: <u>Start Date</u> <u>End Date</u> <u>MTWTFSS</u> <u>Spots/Week</u> <u>Rate</u> 05/09/22 05/15/22 MTWTFSS 2 \$0.00									
Spots: # <u>Ch</u> <u>Day</u> <u>Air Date</u> <u>Air Time</u> <u>Description</u> <u>Start/End Time</u> <u>Length</u> <u>Ad-ID</u> <u>Rate</u> <u>Type</u> 181 WPGX Th 05/12/22 4:59 AM 5a-5x :30 Panama City EEO :30 \$0.00 NM 182 WPGX F 05/13/22 2:29 AM 5a-5x :30 Panama City EEO :30 \$0.00 NM									
Weeks: <u>Start Date</u> <u>End Date</u> <u>MTWTFSS</u> <u>Spots/Week</u> <u>Rate</u> 05/16/22 05/22/22 MTWTFSS 2 \$0.00									
Spots: # <u>Ch</u> <u>Day</u> <u>Air Date</u> <u>Air Time</u> <u>Description</u> <u>Start/End Time</u> <u>Length</u> <u>Ad-ID</u> <u>Rate</u> <u>Type</u> 183 WPGX M 05/16/22 2:19 AM 5a-5x :30 Panama City EEO :30 \$0.00 NM 184 WPGX Sa 05/21/22 1:11 AM 5a-5x :30 Panama City EEO :30 \$0.00 NM									
Weeks: <u>Start Date</u> <u>End Date</u> <u>MTWTFSS</u> <u>Spots/Week</u> <u>Rate</u> 05/23/22 05/29/22 MTWTFSS 2 \$0.00									
Spots: # <u>Ch</u> <u>Day</u> <u>Air Date</u> <u>Air Time</u> <u>Description</u> <u>Start/End Time</u> <u>Length</u> <u>Ad-ID</u> <u>Rate</u> <u>Type</u> 185 WPGX Th 05/26/22 2:29 AM 5a-5x :30 Panama City EEO :30 \$0.00 NM 186 WPGX F 05/27/22 12:58 AM 5a-5x :30 Panama City EEO :30 \$0.00 NM									

**Total Spots 10**

## Payment Terms 30 Days

**Net Total \$0.00**

**Invoice Balance as of 04/18/24 12:42:37 PM ET \$0.00**

We warrant that the actual broadcast information shown on this invoice was taken from the program log. Lockwood Broadcast Group does not discriminate in its advertising contracts, and it will not accept advertising intended to discriminate on the basis of race or ethnicity. Advertiser hereto affirms that nothing in this Agreement is intended to discriminate on the basis of race or ethnicity.

# INVOICE



**WPGX-TV**  
**700 W 23rd St #28**  
**Panama City, FL 32405**  
**Main: (804) 672-6565**  
**Billing: (804) 672-6565**

Property	WPGX		
Invoice #	122020-23	Order #	122020
Invoice Date	06/26/22	Alt Order #	
Invoice Month	June 2022	Deal #	
Invoice Period	05/30/22 - 06/26/22	Flight Dates	08/23/20 - 12/31/24
Advertiser	WPGX-Public Service		
Product	Compliance - EEO		
Estimate #	Compliance - EEO		
Account Executive	WPGX House		
Sales Office	Panama City Local		
Sales Region	Local		
Agency Code			
Advertiser Code			
Billing Calendar	Broadcast		
Billing Type	Cash		
Special Handling	Do Not Mail		
Agency Ref			
Advertiser Ref			
Product 1			
Product 2			

Billing Address:

**WPGX-Public Service**  
**Attention: Accounts Payable**  
**XXXX**  
**XXXX, XX XXXXX**

Send Payment To:

**WPGX-TV**  
**3914 Wistar Road**  
**Richmond, VA 23228**

Line	Start Date	End Date	Description	Start/End Time	MTWTFSS	Length	Spots/ Week	Rate	Type
1	08/23/20	12/31/24		5a-5x	MTWTFSS	:30	2	\$0.00	NM
Weeks: <u>Start Date</u> <u>End Date</u> <u>MTWTFSS</u> <u>Spots/Week</u> <u>Rate</u> 05/30/22 06/05/22 MTWTFSS 2 \$0.00									
Spots: # <u>Ch</u> <u>Day</u> <u>Air Date</u> <u>Air Time</u> <u>Description</u> <u>Start/End Time</u> <u>Length</u> <u>Ad-ID</u> <u>Rate</u> <u>Type</u> 187 WPGX M 05/30/22 1:50 AM 5a-5x :30 Panama City EEO :30 \$0.00 NM 188 WPGX Tu 05/31/22 3:31 PM 5a-5x :30 Panama City EEO :30 \$0.00 NM									
Weeks: <u>Start Date</u> <u>End Date</u> <u>MTWTFSS</u> <u>Spots/Week</u> <u>Rate</u> 06/06/22 06/12/22 MTWTFSS 2 \$0.00									
Spots: # <u>Ch</u> <u>Day</u> <u>Air Date</u> <u>Air Time</u> <u>Description</u> <u>Start/End Time</u> <u>Length</u> <u>Ad-ID</u> <u>Rate</u> <u>Type</u> 189 WPGX M 06/06/22 12:29 PM 5a-5x :30 Panama City EEO :30 \$0.00 NM 190 WPGX Sa 06/11/22 2:29 AM 5a-5x :30 Panama City EEO :30 \$0.00 NM									
Weeks: <u>Start Date</u> <u>End Date</u> <u>MTWTFSS</u> <u>Spots/Week</u> <u>Rate</u> 06/13/22 06/19/22 MTWTFSS 2 \$0.00									
Spots: # <u>Ch</u> <u>Day</u> <u>Air Date</u> <u>Air Time</u> <u>Description</u> <u>Start/End Time</u> <u>Length</u> <u>Ad-ID</u> <u>Rate</u> <u>Type</u> 191 WPGX Tu 06/14/22 6:50 PM 5a-5x :30 Panama City EEO :30 \$0.00 NM 192 WPGX F 06/17/22 2:29 AM 5a-5x :30 Panama City EEO :30 \$0.00 NM									
Weeks: <u>Start Date</u> <u>End Date</u> <u>MTWTFSS</u> <u>Spots/Week</u> <u>Rate</u> 06/20/22 06/26/22 MTWTFSS 2 \$0.00									
Spots: # <u>Ch</u> <u>Day</u> <u>Air Date</u> <u>Air Time</u> <u>Description</u> <u>Start/End Time</u> <u>Length</u> <u>Ad-ID</u> <u>Rate</u> <u>Type</u> 193 WPGX M 06/20/22 1:58 AM 5a-5x :30 Panama City EEO :30 \$0.00 NM 194 WPGX Sa 06/25/22 2:59 AM 5a-5x :30 Panama City EEO :30 \$0.00 NM									

**Total Spots 8**

## Payment Terms 30 Days

Net Total **\$0.00**

Invoice Balance as of 04/18/24 12:42:52 PM ET **\$0.00**

We warrant that the actual broadcast information shown on this invoice was taken from the program log. Lockwood Broadcast Group does not discriminate in its advertising contracts, and it will not accept advertising intended to discriminate on the basis of race or ethnicity. Advertiser hereto affirms that nothing in this Agreement is intended to discriminate on the basis of race or ethnicity.

# INVOICE



**WPGX-TV**  
**700 W 23rd St #28**  
**Panama City, FL 32405**  
**Main: (804) 672-6565**  
**Billing: (804) 672-6565**

Property	WPGX		
Invoice #	122020-24	Order #	122020
Invoice Date	07/31/22	Alt Order #	
Invoice Month	July 2022	Deal #	
Invoice Period	06/27/22 - 07/31/22	Flight Dates	08/23/20 - 12/31/24
Advertiser	WPGX-Public Service		
Product	Compliance - EEO		
Estimate #	Compliance - EEO		
Account Executive	WPGX House		
Sales Office	Panama City Local		
Sales Region	Local		
Agency Code			
Advertiser Code			
Billing Calendar	Broadcast		
Billing Type	Cash		
Special Handling	Do Not Mail		
Agency Ref			
Advertiser Ref			
Product 1			
Product 2			

Billing Address:

**WPGX-Public Service**  
**Attention: Accounts Payable**  
**XXXX**  
**XXXX, XX XXXXX**

Send Payment To:

**WPGX-TV**  
**3914 Wistar Road**  
**Richmond, VA 23228**

Line	Start Date	End Date	Description	Start/End Time	MTWTFSS	Length	Spots/ Week	Rate	Type
1	08/23/20	12/31/24		5a-5x	MTWTFSS	:30	2	\$0.00	NM
Weeks: <u>Start Date</u> <u>End Date</u> <u>MTWTFSS</u> <u>Spots/Week</u> <u>Rate</u> 06/27/22 07/03/22 MTWTFSS 2 \$0.00									
Spots: # <u>Ch</u> <u>Day</u> <u>Air Date</u> <u>Air Time</u> <u>Description</u> <u>Start/End Time</u> <u>Length</u> <u>Ad-ID</u> <u>Rate</u> <u>Type</u> 195 WPGX M 06/27/22 2:40 PM 5a-5x :30 Panama City EEO :30 \$0.00 NM 196 WPGX W 06/29/22 11:13 PM 5a-5x :30 Panama City EEO :30 \$0.00 NM									
Weeks: <u>Start Date</u> <u>End Date</u> <u>MTWTFSS</u> <u>Spots/Week</u> <u>Rate</u> 07/04/22 07/10/22 MTWTFSS 2 \$0.00									
Spots: # <u>Ch</u> <u>Day</u> <u>Air Date</u> <u>Air Time</u> <u>Description</u> <u>Start/End Time</u> <u>Length</u> <u>Ad-ID</u> <u>Rate</u> <u>Type</u> 198 WPGX M 07/04/22 6:19 PM 5a-5x :30 Panama City EEO :30 \$0.00 NM 197 WPGX F 07/08/22 7:59 AM 5a-5x :30 Panama City EEO :30 \$0.00 NM									
Weeks: <u>Start Date</u> <u>End Date</u> <u>MTWTFSS</u> <u>Spots/Week</u> <u>Rate</u> 07/11/22 07/17/22 MTWTFSS 2 \$0.00									
Spots: # <u>Ch</u> <u>Day</u> <u>Air Date</u> <u>Air Time</u> <u>Description</u> <u>Start/End Time</u> <u>Length</u> <u>Ad-ID</u> <u>Rate</u> <u>Type</u> 200 WPGX M 07/11/22 12:14 AM 5a-5x :30 Panama City EEO :30 \$0.00 NM 199 WPGX Tu 07/12/22 2:09 AM 5a-5x :30 Panama City EEO :30 \$0.00 NM									
Weeks: <u>Start Date</u> <u>End Date</u> <u>MTWTFSS</u> <u>Spots/Week</u> <u>Rate</u> 07/18/22 07/24/22 MTWTFSS 2 \$0.00									
Spots: # <u>Ch</u> <u>Day</u> <u>Air Date</u> <u>Air Time</u> <u>Description</u> <u>Start/End Time</u> <u>Length</u> <u>Ad-ID</u> <u>Rate</u> <u>Type</u> 202 WPGX M 07/18/22 2:18 AM 5a-5x :30 Panama City EEO :30 \$0.00 NM 201 WPGX F 07/22/22 1:57 AM 5a-5x :30 Panama City EEO :30 \$0.00 NM									
Weeks: <u>Start Date</u> <u>End Date</u> <u>MTWTFSS</u> <u>Spots/Week</u> <u>Rate</u> 07/25/22 07/31/22 MTWTFSS 2 \$0.00									
Spots: # <u>Ch</u> <u>Day</u> <u>Air Date</u> <u>Air Time</u> <u>Description</u> <u>Start/End Time</u> <u>Length</u> <u>Ad-ID</u> <u>Rate</u> <u>Type</u> 203 WPGX M 07/25/22 1:43 AM 5a-5x :30 Panama City EEO :30 \$0.00 NM 204 WPGX F 07/29/22 1:22 AM 5a-5x :30 Panama City EEO :30 \$0.00 NM									

**Total Spots 10**

## Payment Terms 30 Days

**Net Total \$0.00**

**Invoice Balance as of 04/18/24 12:43:05 PM ET \$0.00**

We warrant that the actual broadcast information shown on this invoice was taken from the program log. Lockwood Broadcast Group does not discriminate in its advertising contracts, and it will not accept advertising intended to discriminate on the basis of race or ethnicity. Advertiser hereto affirms that nothing in this Agreement is intended to discriminate on the basis of race or ethnicity.

# INVOICE



**WPGX-TV**  
**700 W 23rd St #28**  
**Panama City, FL 32405**  
**Main: (804) 672-6565**  
**Billing: (804) 672-6565**

Property	WPGX		
Invoice #	122020-25	Order #	122020
Invoice Date	08/28/22	Alt Order #	
Invoice Month	August 2022	Deal #	
Invoice Period	08/01/22 - 08/28/22	Flight Dates	08/23/20 - 12/31/24
Advertiser	WPGX-Public Service		
Product	Compliance - EEO		
Estimate #	Compliance - EEO		
Account Executive	WPGX House		
Sales Office	Panama City Local		
Sales Region	Local		
Agency Code			
Advertiser Code			
Billing Calendar	Broadcast		
Billing Type	Cash		
Special Handling	Do Not Mail		
Agency Ref			
Advertiser Ref			
Product 1			
Product 2			

Billing Address:

**WPGX-Public Service**  
**Attention: Accounts Payable**  
**XXXX**  
**XXXX, XX XXXXX**

Send Payment To:

**WPGX-TV**  
**3914 Wistar Road**  
**Richmond, VA 23228**

Line	Start Date	End Date	Description	Start/End Time	MTWTFSS	Length	Spots/ Week	Rate	Type
1	08/23/20	12/31/24		5a-5x	MTWTFSS	:30	2	\$0.00	NM
Weeks: <u>Start Date</u> <u>End Date</u> <u>MTWTFSS</u> <u>Spots/Week</u> <u>Rate</u> 08/01/22 08/07/22 MTWTFSS 2 \$0.00									
Spots: # <u>Ch</u> <u>Day</u> <u>Air Date</u> <u>Air Time</u> <u>Description</u> <u>Start/End Time</u> <u>Length</u> <u>Ad-ID</u> <u>Rate</u> <u>Type</u> 205 WPGX M 08/01/22 8:45 AM 5a-5x :30 Panama City EEO :30 \$0.00 NM 206 WPGX Sa 08/06/22 12:29 AM 5a-5x :30 Panama City EEO :30 \$0.00 NM									
Weeks: <u>Start Date</u> <u>End Date</u> <u>MTWTFSS</u> <u>Spots/Week</u> <u>Rate</u> 08/08/22 08/14/22 MTWTFSS 2 \$0.00									
Spots: # <u>Ch</u> <u>Day</u> <u>Air Date</u> <u>Air Time</u> <u>Description</u> <u>Start/End Time</u> <u>Length</u> <u>Ad-ID</u> <u>Rate</u> <u>Type</u> 207 WPGX M 08/08/22 2:08 AM 5a-5x :30 Panama City EEO :30 \$0.00 NM 208 WPGX F 08/12/22 1:49 AM 5a-5x :30 Panama City EEO :30 \$0.00 NM									
Weeks: <u>Start Date</u> <u>End Date</u> <u>MTWTFSS</u> <u>Spots/Week</u> <u>Rate</u> 08/15/22 08/21/22 MTWTFSS 2 \$0.00									
Spots: # <u>Ch</u> <u>Day</u> <u>Air Date</u> <u>Air Time</u> <u>Description</u> <u>Start/End Time</u> <u>Length</u> <u>Ad-ID</u> <u>Rate</u> <u>Type</u> 209 WPGX M 08/15/22 1:13 AM 5a-5x :30 Panama City EEO :30 \$0.00 NM 210 WPGX Sa 08/20/22 12:39 AM 5a-5x :30 Panama City EEO :30 \$0.00 NM									
Weeks: <u>Start Date</u> <u>End Date</u> <u>MTWTFSS</u> <u>Spots/Week</u> <u>Rate</u> 08/22/22 08/28/22 MTWTFSS 2 \$0.00									
Spots: # <u>Ch</u> <u>Day</u> <u>Air Date</u> <u>Air Time</u> <u>Description</u> <u>Start/End Time</u> <u>Length</u> <u>Ad-ID</u> <u>Rate</u> <u>Type</u> 212 WPGX M 08/22/22 1:43 AM 5a-5x :30 Panama City EEO :30 \$0.00 NM 211 WPGX Tu 08/23/22 1:23 AM 5a-5x :30 Panama City EEO :30 \$0.00 NM									

**Total Spots 8**

## Payment Terms 30 Days

<u>Net Total</u>	<b>\$0.00</b>
<u>Invoice Balance as of 04/18/24 12:43:22 PM ET</u>	<b>\$0.00</b>

We warrant that the actual broadcast information shown on this invoice was taken from the program log. Lockwood Broadcast Group does not discriminate in its advertising contracts, and it will not accept advertising intended to discriminate on the basis of race or ethnicity. Advertiser hereto affirms that nothing in this Agreement is intended to discriminate on the basis of race or ethnicity.

# INVOICE



**WPGX-TV**  
**700 W 23rd St #28**  
**Panama City, FL 32405**  
**Main: (804) 672-6565**  
**Billing: (804) 672-6565**

Property	WPGX		
Invoice #	122020-26	Order #	122020
Invoice Date	09/25/22	Alt Order #	
Invoice Month	September 2022	Deal #	
Invoice Period	08/29/22 - 09/25/22	Flight Dates	08/23/20 - 12/31/24
Advertiser	WPGX-Public Service		
Product	Compliance - EEO		
Estimate #	Compliance - EEO		
Account Executive	WPGX House		
Sales Office	Panama City Local		
Sales Region	Local		
Agency Code			
Advertiser Code			
Billing Calendar	Broadcast		
Billing Type	Cash		
Special Handling	Do Not Mail		
Agency Ref			
Advertiser Ref			
Product 1			
Product 2			

Billing Address:

**WPGX-Public Service**  
**Attention: Accounts Payable**  
**XXXX**  
**XXXX, XX XXXXX**

Send Payment To:

**WPGX-TV**  
**3914 Wistar Road**  
**Richmond, VA 23228**

Line	Start Date	End Date	Description	Start/End Time	MTWTFSS	Length	Spots/ Week	Rate	Type
1	08/23/20	12/31/24		5a-5x	MTWTFSS	:30	2	\$0.00	NM
Weeks: <u>Start Date</u> <u>End Date</u> <u>MTWTFSS</u> <u>Spots/Week</u> <u>Rate</u> 08/29/22 09/04/22 MTWTFSS 2 \$0.00									
Spots: # <u>Ch</u> <u>Day</u> <u>Air Date</u> <u>Air Time</u> <u>Description</u> <u>Start/End Time</u> <u>Length</u> <u>Ad-ID</u> <u>Rate</u> <u>Type</u> 213 WPGX M 08/29/22 1:20 AM 5a-5x :30 Panama City EEO :30 \$0.00 NM 214 WPGX Tu 08/30/22 4:39 PM 5a-5x :30 Panama City EEO :30 \$0.00 NM									
Weeks: <u>Start Date</u> <u>End Date</u> <u>MTWTFSS</u> <u>Spots/Week</u> <u>Rate</u> 09/05/22 09/11/22 MTWTFSS 2 \$0.00									
Spots: # <u>Ch</u> <u>Day</u> <u>Air Date</u> <u>Air Time</u> <u>Description</u> <u>Start/End Time</u> <u>Length</u> <u>Ad-ID</u> <u>Rate</u> <u>Type</u> 215 WPGX M 09/05/22 12:59 PM 5a-5x :30 Panama City EEO :30 \$0.00 NM 216 WPGX Sa 09/10/22 1:19 AM 5a-5x :30 Panama City EEO :30 \$0.00 NM									
Weeks: <u>Start Date</u> <u>End Date</u> <u>MTWTFSS</u> <u>Spots/Week</u> <u>Rate</u> 09/12/22 09/18/22 MTWTFSS 2 \$0.00									
Spots: # <u>Ch</u> <u>Day</u> <u>Air Date</u> <u>Air Time</u> <u>Description</u> <u>Start/End Time</u> <u>Length</u> <u>Ad-ID</u> <u>Rate</u> <u>Type</u> 217 WPGX F 09/16/22 3:53 PM 5a-5x :30 Panama City EEO :30 \$0.00 NM 218 WPGX Sa 09/17/22 4:21 AM 5a-5x :30 Panama City EEO :30 \$0.00 NM									
Weeks: <u>Start Date</u> <u>End Date</u> <u>MTWTFSS</u> <u>Spots/Week</u> <u>Rate</u> 09/19/22 09/25/22 MTWTFSS 2 \$0.00									
Spots: # <u>Ch</u> <u>Day</u> <u>Air Date</u> <u>Air Time</u> <u>Description</u> <u>Start/End Time</u> <u>Length</u> <u>Ad-ID</u> <u>Rate</u> <u>Type</u> 219 WPGX M 09/19/22 8:46 AM 5a-5x :30 Panama City EEO :30 \$0.00 NM 220 WPGX Tu 09/20/22 12:26 AM 5a-5x :30 Panama City EEO :30 \$0.00 NM									

**Total Spots 8**

## Payment Terms 30 Days

<u>Net Total</u>	<b>\$0.00</b>
<u>Invoice Balance as of 04/18/24 12:43:36 PM ET</u>	<b>\$0.00</b>

We warrant that the actual broadcast information shown on this invoice was taken from the program log. Lockwood Broadcast Group does not discriminate in its advertising contracts, and it will not accept advertising intended to discriminate on the basis of race or ethnicity. Advertiser hereto affirms that nothing in this Agreement is intended to discriminate on the basis of race or ethnicity.

# INVOICE



**WPGX-TV**  
**700 W 23rd St #28**  
**Panama City, FL 32405**  
**Main: (804) 672-6565**  
**Billing: (804) 672-6565**

Property	WPGX		
Invoice #	122020-27	Order #	122020
Invoice Date	10/30/22	Alt Order #	
Invoice Month	October 2022	Deal #	
Invoice Period	09/26/22 - 10/30/22	Flight Dates	08/23/20 - 12/31/24
Advertiser	WPGX-Public Service		
Product	Compliance - EEO		
Estimate #	Compliance - EEO		
Account Executive	WPGX House		
Sales Office	Panama City Local		
Sales Region	Local		
Agency Code			
Advertiser Code			
Billing Calendar	Broadcast		
Billing Type	Cash		
Special Handling	Do Not Mail		
Agency Ref			
Advertiser Ref			
Product 1			
Product 2			

Billing Address:

**WPGX-Public Service**  
**Attention: Accounts Payable**  
**XXXX**  
**XXXX, XX XXXXX**

Send Payment To:

**WPGX-TV**  
**3914 Wistar Road**  
**Richmond, VA 23228**

Line	Start Date	End Date	Description	Start/End Time	MTWTFSS	Length	Spots/ Week	Rate	Type
1	08/23/20	12/31/24		5a-5x	MTWTFSS	:30	2	\$0.00	NM
Weeks: <u>Start Date</u> <u>End Date</u> <u>MTWTFSS</u> <u>Spots/Week</u> <u>Rate</u> 09/26/22 10/02/22 MTWTFSS 2 \$0.00									
Spots: # <u>Ch</u> <u>Day</u> <u>Air Date</u> <u>Air Time</u> <u>Description</u> <u>Start/End Time</u> <u>Length</u> <u>Ad-ID</u> <u>Rate</u> <u>Type</u> 222 WPGX M 09/26/22 3:24 PM 5a-5x :30 Panama City EEO :30 \$0.00 NM 221 WPGX F 09/30/22 8:59 AM 5a-5x :30 Panama City EEO :30 \$0.00 NM									
Weeks: <u>Start Date</u> <u>End Date</u> <u>MTWTFSS</u> <u>Spots/Week</u> <u>Rate</u> 10/03/22 10/09/22 MTWTFSS 2 \$0.00									
Spots: # <u>Ch</u> <u>Day</u> <u>Air Date</u> <u>Air Time</u> <u>Description</u> <u>Start/End Time</u> <u>Length</u> <u>Ad-ID</u> <u>Rate</u> <u>Type</u> 223 WPGX M 10/03/22 1:31 AM 5a-5x :30 Panama City EEO :30 \$0.00 NM 224 WPGX Sa 10/08/22 3:59 AM 5a-5x :30 Panama City EEO :30 \$0.00 NM									
Weeks: <u>Start Date</u> <u>End Date</u> <u>MTWTFSS</u> <u>Spots/Week</u> <u>Rate</u> 10/10/22 10/16/22 MTWTFSS 2 \$0.00									
Spots: # <u>Ch</u> <u>Day</u> <u>Air Date</u> <u>Air Time</u> <u>Description</u> <u>Start/End Time</u> <u>Length</u> <u>Ad-ID</u> <u>Rate</u> <u>Type</u> 226 WPGX M 10/10/22 11:55 PM 5a-5x :30 Panama City EEO :30 \$0.00 NM 225 WPGX F 10/14/22 9:17 AM 5a-5x :30 Panama City EEO :30 \$0.00 NM									
Weeks: <u>Start Date</u> <u>End Date</u> <u>MTWTFSS</u> <u>Spots/Week</u> <u>Rate</u> 10/17/22 10/23/22 MTWTFSS 2 \$0.00									
Spots: # <u>Ch</u> <u>Day</u> <u>Air Date</u> <u>Air Time</u> <u>Description</u> <u>Start/End Time</u> <u>Length</u> <u>Ad-ID</u> <u>Rate</u> <u>Type</u> 227 WPGX M 10/17/22 3:59 AM 5a-5x :30 Panama City EEO :30 \$0.00 NM 228 WPGX Tu 10/18/22 1:50 AM 5a-5x :30 Panama City EEO :30 \$0.00 NM									
Weeks: <u>Start Date</u> <u>End Date</u> <u>MTWTFSS</u> <u>Spots/Week</u> <u>Rate</u> 10/24/22 10/30/22 MTWTFSS 2 \$0.00									
Spots: # <u>Ch</u> <u>Day</u> <u>Air Date</u> <u>Air Time</u> <u>Description</u> <u>Start/End Time</u> <u>Length</u> <u>Ad-ID</u> <u>Rate</u> <u>Type</u> 230 WPGX M 10/24/22 6:29 AM 5a-5x :30 Panama City EEO :30 \$0.00 NM 229 WPGX F 10/28/22 1:56 AM 5a-5x :30 Panama City EEO :30 \$0.00 NM									

**Total Spots 10**

## Payment Terms 30 Days

**Net Total \$0.00**

**Invoice Balance as of 04/18/24 12:43:48 PM ET \$0.00**

We warrant that the actual broadcast information shown on this invoice was taken from the program log. Lockwood Broadcast Group does not discriminate in its advertising contracts, and it will not accept advertising intended to discriminate on the basis of race or ethnicity. Advertiser hereto affirms that nothing in this Agreement is intended to discriminate on the basis of race or ethnicity.

# INVOICE



**WPGX-TV**  
**700 W 23rd St #28**  
**Panama City, FL 32405**  
**Main: (804) 672-6565**  
**Billing: (804) 672-6565**

Property	WPGX		
Invoice #	122020-28	Order #	122020
Invoice Date	11/27/22	Alt Order #	
Invoice Month	November 2022	Deal #	
Invoice Period	10/31/22 - 11/27/22	Flight Dates	08/23/20 - 12/31/24
Advertiser	WPGX-Public Service		
Product	Compliance - EEO		
Estimate #	Compliance - EEO		
Account Executive	WPGX House		
Sales Office	Panama City Local		
Sales Region	Local		
Agency Code			
Advertiser Code			
Billing Calendar	Broadcast		
Billing Type	Cash		
Special Handling	Do Not Mail		
Agency Ref			
Advertiser Ref			
Product 1			
Product 2			

Billing Address:

**WPGX-Public Service**  
**Attention: Accounts Payable**  
**XXXX**  
**XXXX, XX XXXXX**

Send Payment To:

**WPGX-TV**  
**3914 Wistar Road**  
**Richmond, VA 23228**

Line	Start Date	End Date	Description	Start/End Time	MTWTFSS	Length	Spots/ Week	Rate	Type
1	08/23/20	12/31/24		5a-5x	MTWTFSS	:30	2	\$0.00	NM
Weeks: <u>Start Date</u> <u>End Date</u> <u>MTWTFSS</u> <u>Spots/Week</u> <u>Rate</u> 10/31/22 11/06/22 MTWTFSS 2 \$0.00									
Spots: # <u>Ch</u> <u>Day</u> <u>Air Date</u> <u>Air Time</u> <u>Description</u> <u>Start/End Time</u> <u>Length</u> <u>Ad-ID</u> <u>Rate</u> <u>Type</u> 231 WPGX M 10/31/22 5a-5x :00 <del>\$0.00</del> NM Unresolved Did Not Air 232 WPGX Tu 11/01/22 2:19 AM 5a-5x :30 Panama City EEO :30 \$0.00 NM Weeks: <u>Start Date</u> <u>End Date</u> <u>MTWTFSS</u> <u>Spots/Week</u> <u>Rate</u> 11/07/22 11/13/22 MTWTFSS 2 \$0.00									
Spots: # <u>Ch</u> <u>Day</u> <u>Air Date</u> <u>Air Time</u> <u>Description</u> <u>Start/End Time</u> <u>Length</u> <u>Ad-ID</u> <u>Rate</u> <u>Type</u> 233 WPGX W 11/09/22 2:20 AM 5a-5x :30 Panama City EEO :30 \$0.00 NM 234 WPGX Sa 11/12/22 2:20 AM 5a-5x :30 Panama City EEO :30 \$0.00 NM Weeks: <u>Start Date</u> <u>End Date</u> <u>MTWTFSS</u> <u>Spots/Week</u> <u>Rate</u> 11/14/22 11/20/22 MTWTFSS 2 \$0.00									
Spots: # <u>Ch</u> <u>Day</u> <u>Air Date</u> <u>Air Time</u> <u>Description</u> <u>Start/End Time</u> <u>Length</u> <u>Ad-ID</u> <u>Rate</u> <u>Type</u> 236 WPGX M 11/14/22 12:14 AM 5a-5x :30 Panama City EEO :30 \$0.00 NM 235 WPGX Sa 11/19/22 3:49 AM 5a-5x :30 Panama City EEO :30 \$0.00 NM Weeks: <u>Start Date</u> <u>End Date</u> <u>MTWTFSS</u> <u>Spots/Week</u> <u>Rate</u> 11/21/22 11/27/22 MTWTFSS 2 \$0.00									
Spots: # <u>Ch</u> <u>Day</u> <u>Air Date</u> <u>Air Time</u> <u>Description</u> <u>Start/End Time</u> <u>Length</u> <u>Ad-ID</u> <u>Rate</u> <u>Type</u> 238 WPGX M 11/21/22 2:25 AM 5a-5x :30 Panama City EEO :30 \$0.00 NM 237 WPGX F 11/25/22 2:19 AM 5a-5x :30 Panama City EEO :30 \$0.00 NM									

Total Spots 7

## Payment Terms 30 Days

Net Total \$0.00

Invoice Balance as of 04/18/24 12:44:05 PM ET \$0.00

We warrant that the actual broadcast information shown on this invoice was taken from the program log. Lockwood Broadcast Group does not discriminate in its advertising contracts, and it will not accept advertising intended to discriminate on the basis of race or ethnicity. Advertiser hereto affirms that nothing in this Agreement is intended to discriminate on the basis of race or ethnicity.



# INVOICE



**WPGX-TV**  
**700 W 23rd St #28**  
**Panama City, FL 32405**  
**Main: (804) 672-6565**  
**Billing: (804) 672-6565**

Property	WPGX		
Invoice #	122020-29	Order #	122020
Invoice Date	12/25/22	Alt Order #	
Invoice Month	December 2022	Deal #	
Invoice Period	11/28/22 - 12/25/22	Flight Dates	08/23/20 - 12/31/24
Advertiser	WPGX-Public Service		
Product	Compliance - EEO		
Estimate #	Compliance - EEO		
Account Executive	WPGX House		
Sales Office	Panama City Local		
Sales Region	Local		
Agency Code			
Advertiser Code			
Billing Calendar	Broadcast		
Billing Type	Cash		
Special Handling	Do Not Mail		
Agency Ref			
Advertiser Ref			
Product 1			
Product 2			

Billing Address:

**WPGX-Public Service**  
**Attention: Accounts Payable**  
**XXXX**  
**XXXX, XX XXXXX**

Send Payment To:

**WPGX-TV**  
**3914 Wistar Road**  
**Richmond, VA 23228**

Line	Start Date	End Date	Description	Start/End Time	MTWTFSS	Length	Spots/ Week	Rate	Type
1	08/23/20	12/31/24		5a-5x	MTWTFSS	:30	2	\$0.00	NM
Weeks: <u>Start Date</u> <u>End Date</u> <u>MTWTFSS</u> <u>Spots/Week</u> <u>Rate</u> 11/28/22 12/04/22 MTWTFSS 2 \$0.00									
Spots: # <u>Ch</u> <u>Day</u> <u>Air Date</u> <u>Air Time</u> <u>Description</u> <u>Start/End Time</u> <u>Length</u> <u>Ad-ID</u> <u>Rate</u> <u>Type</u> 240 WPGX M 11/28/22 1:44 AM 5a-5x :30 Panama City EEO :30 \$0.00 NM 239 WPGX Tu 11/29/22 3:46 AM 5a-5x :30 Panama City EEO :30 \$0.00 NM									
Weeks: <u>Start Date</u> <u>End Date</u> <u>MTWTFSS</u> <u>Spots/Week</u> <u>Rate</u> 12/05/22 12/11/22 MTWTFSS 2 \$0.00									
Spots: # <u>Ch</u> <u>Day</u> <u>Air Date</u> <u>Air Time</u> <u>Description</u> <u>Start/End Time</u> <u>Length</u> <u>Ad-ID</u> <u>Rate</u> <u>Type</u> 241 WPGX M 12/05/22 2:19 AM 5a-5x :30 Panama City EEO :30 \$0.00 NM 242 WPGX Sa 12/10/22 5:59 AM 5a-5x :30 Panama City EEO :30 \$0.00 NM									
Weeks: <u>Start Date</u> <u>End Date</u> <u>MTWTFSS</u> <u>Spots/Week</u> <u>Rate</u> 12/12/22 12/18/22 MTWTFSS 2 \$0.00									
Spots: # <u>Ch</u> <u>Day</u> <u>Air Date</u> <u>Air Time</u> <u>Description</u> <u>Start/End Time</u> <u>Length</u> <u>Ad-ID</u> <u>Rate</u> <u>Type</u> 244 WPGX M 12/12/22 10:44 PM 5a-5x :30 Panama City EEO :30 \$0.00 NM 243 WPGX Tu 12/13/22 5:59 PM 5a-5x :30 Panama City EEO :30 \$0.00 NM									
Weeks: <u>Start Date</u> <u>End Date</u> <u>MTWTFSS</u> <u>Spots/Week</u> <u>Rate</u> 12/19/22 12/25/22 MTWTFSS 2 \$0.00									
Spots: # <u>Ch</u> <u>Day</u> <u>Air Date</u> <u>Air Time</u> <u>Description</u> <u>Start/End Time</u> <u>Length</u> <u>Ad-ID</u> <u>Rate</u> <u>Type</u> 245 WPGX M 12/19/22 1:57 AM 5a-5x :30 Panama City EEO :30 \$0.00 NM 246 WPGX F 12/23/22 2:10 AM 5a-5x :30 Panama City EEO :30 \$0.00 NM									

**Total Spots 8**

## Payment Terms 30 Days

<u>Net Total</u>	<b>\$0.00</b>
<u>Invoice Balance as of 04/18/24 12:44:17 PM ET</u>	<b>\$0.00</b>

We warrant that the actual broadcast information shown on this invoice was taken from the program log. Lockwood Broadcast Group does not discriminate in its advertising contracts, and it will not accept advertising intended to discriminate on the basis of race or ethnicity. Advertiser hereto affirms that nothing in this Agreement is intended to discriminate on the basis of race or ethnicity.

# INVOICE



**WPGX-TV**  
**700 W 23rd St #28**  
**Panama City, FL 32405**  
**Main: (804) 672-6565**  
**Billing: (804) 672-6565**

Property	WPGX		
Invoice #	122020-30	Order #	122020
Invoice Date	01/29/23	Alt Order #	
Invoice Month	January 2023	Deal #	
Invoice Period	12/26/22 - 01/29/23	Flight Dates	08/23/20 - 12/31/24
Advertiser	WPGX-Public Service		
Product	Compliance - EEO		
Estimate #	Compliance - EEO		
Account Executive	WPGX House		
Sales Office	Panama City Local		
Sales Region	Local		
Agency Code			
Advertiser Code			
Billing Calendar	Broadcast		
Billing Type	Cash		
Special Handling	Do Not Mail		
Agency Ref			
Advertiser Ref			
Product 1			
Product 2			

Billing Address:

**WPGX-Public Service**  
**Attention: Accounts Payable**  
**XXXX**  
**XXXX, XX XXXXX**

Send Payment To:

**WPGX-TV**  
**3914 Wistar Road**  
**Richmond, VA 23228**

Line	Start Date	End Date	Description	Start/End Time	MTWTFSS	Length	Spots/ Week	Rate	Type
1	08/23/20	12/31/24		5a-5x	MTWTFSS	:30	2	\$0.00	NM
Weeks: <u>Start Date</u> <u>End Date</u> <u>MTWTFSS</u> <u>Spots/Week</u> <u>Rate</u> 12/26/22 01/01/23 MTWTFSS- 2 \$0.00									
Spots: # <u>Ch</u> <u>Day</u> <u>Air Date</u> <u>Air Time</u> <u>Description</u> <u>Start/End Time</u> <u>Length</u> <u>Ad-ID</u> <u>Rate</u> <u>Type</u> 247 WPGX M 12/26/22 1:13 PM 5a-5x :30 Panama City EEO :30 \$0.00 NM 248 WPGX F 12/30/22 4:41 PM 5a-5x :30 Panama City EEO :30 \$0.00 NM									
Weeks: <u>Start Date</u> <u>End Date</u> <u>MTWTFSS</u> <u>Spots/Week</u> <u>Rate</u> 01/02/23 01/08/23 MTWTFSS 2 \$0.00									
Spots: # <u>Ch</u> <u>Day</u> <u>Air Date</u> <u>Air Time</u> <u>Description</u> <u>Start/End Time</u> <u>Length</u> <u>Ad-ID</u> <u>Rate</u> <u>Type</u> 250 WPGX W 01/04/23 1:55 AM 5a-5x :30 Panama City EEO :30 \$0.00 NM 249 WPGX Su 01/08/23 3:59 AM 5a-5x :30 Panama City EEO :30 \$0.00 NM									
Weeks: <u>Start Date</u> <u>End Date</u> <u>MTWTFSS</u> <u>Spots/Week</u> <u>Rate</u> 01/09/23 01/15/23 MTWTFSS 2 \$0.00									
Spots: # <u>Ch</u> <u>Day</u> <u>Air Date</u> <u>Air Time</u> <u>Description</u> <u>Start/End Time</u> <u>Length</u> <u>Ad-ID</u> <u>Rate</u> <u>Type</u> 252 WPGX W 01/11/23 3:29 AM 5a-5x :30 Panama City EEO :30 \$0.00 NM 251 WPGX Su 01/15/23 6:59 AM 5a-5x :30 Panama City EEO :30 \$0.00 NM									
Weeks: <u>Start Date</u> <u>End Date</u> <u>MTWTFSS</u> <u>Spots/Week</u> <u>Rate</u> 01/16/23 01/22/23 MTWTFSS 2 \$0.00									
Spots: # <u>Ch</u> <u>Day</u> <u>Air Date</u> <u>Air Time</u> <u>Description</u> <u>Start/End Time</u> <u>Length</u> <u>Ad-ID</u> <u>Rate</u> <u>Type</u> 254 WPGX Th 01/19/23 1:52 PM 5a-5x :30 Panama City EEO :30 \$0.00 NM 253 WPGX Su 01/22/23 4:29 PM 5a-5x :30 Panama City EEO :30 \$0.00 NM									
Weeks: <u>Start Date</u> <u>End Date</u> <u>MTWTFSS</u> <u>Spots/Week</u> <u>Rate</u> 01/23/23 01/29/23 MTWTFSS 2 \$0.00									
Spots: # <u>Ch</u> <u>Day</u> <u>Air Date</u> <u>Air Time</u> <u>Description</u> <u>Start/End Time</u> <u>Length</u> <u>Ad-ID</u> <u>Rate</u> <u>Type</u> 256 WPGX Th 01/26/23 12:42 AM 5a-5x :30 Panama City EEO :30 \$0.00 NM 255 WPGX Su 01/29/23 4:29 AM 5a-5x :30 Panama City EEO :30 \$0.00 NM									

**Total Spots 10**

## Payment Terms 30 Days

**Net Total \$0.00**

**Invoice Balance as of 04/18/24 12:45:20 PM ET \$0.00**

We warrant that the actual broadcast information shown on this invoice was taken from the program log. Lockwood Broadcast Group does not discriminate in its advertising contracts, and it will not accept advertising intended to discriminate on the basis of race or ethnicity. Advertiser hereto affirms that nothing in this Agreement is intended to discriminate on the basis of race or ethnicity.

# INVOICE



**WPGX-TV**  
**700 W 23rd St #28**  
**Panama City, FL 32405**  
**Main: (804) 672-6565**  
**Billing: (804) 672-6565**

Property	WPGX		
Invoice #	122020-31	Order #	122020
Invoice Date	02/26/23	Alt Order #	
Invoice Month	February 2023	Deal #	
Invoice Period	01/30/23 - 02/26/23	Flight Dates	08/23/20 - 12/31/24
Advertiser	WPGX-Public Service		
Product	Compliance - EEO		
Estimate #	Compliance - EEO		
Account Executive	WPGX House		
Sales Office	Panama City Local		
Sales Region	Local		
Agency Code			
Advertiser Code			
Billing Calendar	Broadcast		
Billing Type	Cash		
Special Handling	Do Not Mail		
Agency Ref			
Advertiser Ref			
Product 1			
Product 2			

Billing Address:

**WPGX-Public Service**  
**Attention: Accounts Payable**  
**XXXX**  
**XXXX, XX XXXXX**

Send Payment To:

**WPGX-TV**  
**3914 Wistar Road**  
**Richmond, VA 23228**

Line	Start Date	End Date	Description	Start/End Time	MTWTFSS	Length	Spots/ Week	Rate	Type
1	08/23/20	12/31/24		5a-5x	MTWTFSS	:30	2	\$0.00	NM
Weeks: <u>Start Date</u> <u>End Date</u> <u>MTWTFSS</u> <u>Spots/Week</u> <u>Rate</u> 01/30/23 02/05/23 MTWTFSS 2 \$0.00									
Spots: # <u>Ch</u> <u>Day</u> <u>Air Date</u> <u>Air Time</u> <u>Description</u> <u>Start/End Time</u> <u>Length</u> <u>Ad-ID</u> <u>Rate</u> <u>Type</u> 258 WPGX W 02/01/23 5:59 PM 5a-5x :30 Panama City EEO :30 \$0.00 NM 257 WPGX Su 02/05/23 12:15 AM 5a-5x :30 Panama City EEO :30 \$0.00 NM									
Weeks: <u>Start Date</u> <u>End Date</u> <u>MTWTFSS</u> <u>Spots/Week</u> <u>Rate</u> 02/06/23 02/12/23 MTWTFSS 2 \$0.00									
Spots: # <u>Ch</u> <u>Day</u> <u>Air Date</u> <u>Air Time</u> <u>Description</u> <u>Start/End Time</u> <u>Length</u> <u>Ad-ID</u> <u>Rate</u> <u>Type</u> 260 WPGX Th 02/09/23 9:46 AM 5a-5x :30 Panama City EEO :30 \$0.00 NM 259 WPGX Su 02/12/23 1:37 AM 5a-5x :30 Panama City EEO :30 \$0.00 NM									
Weeks: <u>Start Date</u> <u>End Date</u> <u>MTWTFSS</u> <u>Spots/Week</u> <u>Rate</u> 02/13/23 02/19/23 MTWTFSS 2 \$0.00									
Spots: # <u>Ch</u> <u>Day</u> <u>Air Date</u> <u>Air Time</u> <u>Description</u> <u>Start/End Time</u> <u>Length</u> <u>Ad-ID</u> <u>Rate</u> <u>Type</u> 262 WPGX W 02/15/23 12:21 PM 5a-5x :30 Panama City EEO :30 \$0.00 NM 261 WPGX F 02/17/23 3:59 AM 5a-5x :30 Panama City EEO :30 \$0.00 NM									
Weeks: <u>Start Date</u> <u>End Date</u> <u>MTWTFSS</u> <u>Spots/Week</u> <u>Rate</u> 02/20/23 02/26/23 MTWTFSS 2 \$0.00									
Spots: # <u>Ch</u> <u>Day</u> <u>Air Date</u> <u>Air Time</u> <u>Description</u> <u>Start/End Time</u> <u>Length</u> <u>Ad-ID</u> <u>Rate</u> <u>Type</u> 264 WPGX W 02/22/23 4:29 AM 5a-5x :30 Panama City EEO :30 \$0.00 NM 263 WPGX Su 02/26/23 3:29 AM 5a-5x :30 Panama City EEO :30 \$0.00 NM									

**Total Spots 8**

## Payment Terms 30 Days

Net Total **\$0.00**

Invoice Balance as of 04/18/24 12:44:57 PM ET **\$0.00**

We warrant that the actual broadcast information shown on this invoice was taken from the program log. Lockwood Broadcast Group does not discriminate in its advertising contracts, and it will not accept advertising intended to discriminate on the basis of race or ethnicity. Advertiser hereto affirms that nothing in this Agreement is intended to discriminate on the basis of race or ethnicity.

# INVOICE



**WPGX-TV**  
**700 W 23rd St #28**  
**Panama City, FL 32405**  
**Main: (804) 672-6565**  
**Billing: (804) 672-6565**

Property	WPGX		
Invoice #	122020-32	Order #	122020
Invoice Date	03/26/23	Alt Order #	
Invoice Month	March 2023	Deal #	
Invoice Period	02/27/23 - 03/26/23	Flight Dates	08/23/20 - 12/31/24
Advertiser	WPGX-Public Service		
Product	Compliance - EEO		
Estimate #	Compliance - EEO		
Account Executive	WPGX House		
Sales Office	Panama City Local		
Sales Region	Local		
Agency Code			
Advertiser Code			
Billing Calendar	Broadcast		
Billing Type	Cash		
Special Handling	Do Not Mail		
Agency Ref			
Advertiser Ref			
Product 1			
Product 2			

Billing Address:

**WPGX-Public Service**  
**Attention: Accounts Payable**  
**XXXX**  
**XXXX, XX XXXXX**

Send Payment To:

**WPGX-TV**  
**3914 Wistar Road**  
**Richmond, VA 23228**

Line	Start Date	End Date	Description	Start/End Time	MTWTFSS	Length	Spots/ Week	Rate	Type
1	08/23/20	12/31/24		5a-5x	MTWTFSS	:30	2	\$0.00	NM
Weeks: <u>Start Date</u> <u>End Date</u> <u>MTWTFSS</u> <u>Spots/Week</u> <u>Rate</u> 02/27/23 03/05/23 MTWTFSS 2 \$0.00									
Spots: # <u>Ch</u> <u>Day</u> <u>Air Date</u> <u>Air Time</u> <u>Description</u> <u>Start/End Time</u> <u>Length</u> <u>Ad-ID</u> <u>Rate</u> <u>Type</u> 266 WPGX Th 03/02/23 2:29 AM 5a-5x :30 Panama City EEO :30 \$0.00 NM 265 WPGX Su 03/05/23 12:29 AM 5a-5x :30 Panama City EEO :30 \$0.00 NM									
Weeks: <u>Start Date</u> <u>End Date</u> <u>MTWTFSS</u> <u>Spots/Week</u> <u>Rate</u> 03/06/23 03/12/23 MTWTFSS 2 \$0.00									
Spots: # <u>Ch</u> <u>Day</u> <u>Air Date</u> <u>Air Time</u> <u>Description</u> <u>Start/End Time</u> <u>Length</u> <u>Ad-ID</u> <u>Rate</u> <u>Type</u> 267 WPGX W 03/08/23 1:11 AM 5a-5x :30 Panama City EEO :30 \$0.00 NM 268 WPGX Su 03/12/23 4:29 AM 5a-5x :30 Panama City EEO :30 \$0.00 NM									
Weeks: <u>Start Date</u> <u>End Date</u> <u>MTWTFSS</u> <u>Spots/Week</u> <u>Rate</u> 03/13/23 03/19/23 MTWTFSS 2 \$0.00									
Spots: # <u>Ch</u> <u>Day</u> <u>Air Date</u> <u>Air Time</u> <u>Description</u> <u>Start/End Time</u> <u>Length</u> <u>Ad-ID</u> <u>Rate</u> <u>Type</u> 269 WPGX Th 03/16/23 8:59 AM 5a-5x :30 Panama City EEO :30 \$0.00 NM 270 WPGX Su 03/19/23 5:29 AM 5a-5x :30 Panama City EEO :30 \$0.00 NM									
Weeks: <u>Start Date</u> <u>End Date</u> <u>MTWTFSS</u> <u>Spots/Week</u> <u>Rate</u> 03/20/23 03/26/23 MTWTFSS 2 \$0.00									
Spots: # <u>Ch</u> <u>Day</u> <u>Air Date</u> <u>Air Time</u> <u>Description</u> <u>Start/End Time</u> <u>Length</u> <u>Ad-ID</u> <u>Rate</u> <u>Type</u> 271 WPGX W 03/22/23 2:19 AM 5a-5x :30 Panama City EEO :30 \$0.00 NM 272 WPGX Th 03/23/23 12:42 AM 5a-5x :30 Panama City EEO :30 \$0.00 NM									

**Total Spots 8**

## Payment Terms 30 Days

Net Total **\$0.00**

Invoice Balance as of 04/18/24 12:45:40 PM ET **\$0.00**

We warrant that the actual broadcast information shown on this invoice was taken from the program log. Lockwood Broadcast Group does not discriminate in its advertising contracts, and it will not accept advertising intended to discriminate on the basis of race or ethnicity. Advertiser hereto affirms that nothing in this Agreement is intended to discriminate on the basis of race or ethnicity.

# INVOICE



**WPGX-TV**  
**700 W 23rd St #28**  
**Panama City, FL 32405**  
**Main: (804) 672-6565**  
**Billing: (804) 672-6565**

Property	WPGX		
Invoice #	122020-33	Order #	122020
Invoice Date	04/30/23	Alt Order #	
Invoice Month	April 2023	Deal #	
Invoice Period	03/27/23 - 04/30/23	Flight Dates	08/23/20 - 12/31/24
Advertiser	WPGX-Public Service		
Product	Compliance - EEO		
Estimate #	Compliance - EEO		
Account Executive	WPGX House		
Sales Office	Panama City Local		
Sales Region	Local		
Agency Code			
Advertiser Code			
Billing Calendar	Broadcast		
Billing Type	Cash		
Special Handling	Do Not Mail		
Agency Ref			
Advertiser Ref			
Product 1			
Product 2			

Billing Address:

**WPGX-Public Service**  
**Attention: Accounts Payable**  
**XXXX**  
**XXXX, XX XXXXX**

Send Payment To:

**WPGX-TV**  
**3914 Wistar Road**  
**Richmond, VA 23228**

Line	Start Date	End Date	Description	Start/End Time	MTWTFSS	Length	Spots/ Week	Rate	Type
1	08/23/20	12/31/24		5a-5x	MTWTFSS	:30	2	\$0.00	NM
Weeks: <u>Start Date</u> <u>End Date</u> <u>MTWTFSS</u> <u>Spots/Week</u> <u>Rate</u> 03/27/23 04/02/23 MTWTFSS 2 \$0.00									
Spots: # <u>Ch</u> <u>Day</u> <u>Air Date</u> <u>Air Time</u> <u>Description</u> <u>Start/End Time</u> <u>Length</u> <u>Ad-ID</u> <u>Rate</u> <u>Type</u> 273 WPGX M 03/27/23 4:29 AM 5a-5x :30 Panama City EEO :30 \$0.00 NM 274 WPGX Tu 03/28/23 11:11 PM 5a-5x :30 Panama City EEO :30 \$0.00 NM									
Weeks: <u>Start Date</u> <u>End Date</u> <u>MTWTFSS</u> <u>Spots/Week</u> <u>Rate</u> 04/03/23 04/09/23 MTWTFSS 2 \$0.00									
Spots: # <u>Ch</u> <u>Day</u> <u>Air Date</u> <u>Air Time</u> <u>Description</u> <u>Start/End Time</u> <u>Length</u> <u>Ad-ID</u> <u>Rate</u> <u>Type</u> 276 WPGX M 04/03/23 8:50 AM 5a-5x :30 Panama City EEO :30 \$0.00 NM 275 WPGX Tu 04/04/23 5:59 PM 5a-5x :30 Panama City EEO :30 \$0.00 NM									
Weeks: <u>Start Date</u> <u>End Date</u> <u>MTWTFSS</u> <u>Spots/Week</u> <u>Rate</u> 04/10/23 04/16/23 MTWTFSS 2 \$0.00									
Spots: # <u>Ch</u> <u>Day</u> <u>Air Date</u> <u>Air Time</u> <u>Description</u> <u>Start/End Time</u> <u>Length</u> <u>Ad-ID</u> <u>Rate</u> <u>Type</u> 277 WPGX M 04/10/23 6:59 AM 5a-5x :30 Panama City EEO :30 \$0.00 NM 278 WPGX Tu 04/11/23 4:29 AM 5a-5x :30 Panama City EEO :30 \$0.00 NM									
Weeks: <u>Start Date</u> <u>End Date</u> <u>MTWTFSS</u> <u>Spots/Week</u> <u>Rate</u> 04/17/23 04/23/23 MTWTFSS 2 \$0.00									
Spots: # <u>Ch</u> <u>Day</u> <u>Air Date</u> <u>Air Time</u> <u>Description</u> <u>Start/End Time</u> <u>Length</u> <u>Ad-ID</u> <u>Rate</u> <u>Type</u> 279 WPGX M 04/17/23 2:10 AM 5a-5x :30 Panama City EEO :30 \$0.00 NM 280 WPGX Tu 04/18/23 1:57 AM 5a-5x :30 Panama City EEO :30 \$0.00 NM									
Weeks: <u>Start Date</u> <u>End Date</u> <u>MTWTFSS</u> <u>Spots/Week</u> <u>Rate</u> 04/24/23 04/30/23 MTWTFSS 2 \$0.00									
Spots: # <u>Ch</u> <u>Day</u> <u>Air Date</u> <u>Air Time</u> <u>Description</u> <u>Start/End Time</u> <u>Length</u> <u>Ad-ID</u> <u>Rate</u> <u>Type</u> 282 WPGX M 04/24/23 12:51 AM 5a-5x :30 Panama City EEO :30 \$0.00 NM 281 WPGX Tu 04/25/23 2:25 AM 5a-5x :30 Panama City EEO :30 \$0.00 NM									

**Total Spots 10**

## Payment Terms 30 Days

**Net Total \$0.00**

**Invoice Balance as of 04/18/24 12:45:52 PM ET \$0.00**

We warrant that the actual broadcast information shown on this invoice was taken from the program log. Lockwood Broadcast Group does not discriminate in its advertising contracts, and it will not accept advertising intended to discriminate on the basis of race or ethnicity. Advertiser hereto affirms that nothing in this Agreement is intended to discriminate on the basis of race or ethnicity.

# INVOICE



**WPGX-TV**  
**700 W 23rd St #28**  
**Panama City, FL 32405**  
**Main: (804) 672-6565**  
**Billing: (804) 672-6565**

Property	WPGX		
Invoice #	122020-34	Order #	122020
Invoice Date	05/28/23	Alt Order #	
Invoice Month	May 2023	Deal #	
Invoice Period	05/01/23 - 05/28/23	Flight Dates	08/23/20 - 12/31/24
Advertiser	WPGX-Public Service		
Product	Compliance - EEO		
Estimate #	Compliance - EEO		
Account Executive	WPGX House		
Sales Office	Panama City Local		
Sales Region	Local		
Agency Code			
Advertiser Code			
Billing Calendar	Broadcast		
Billing Type	Cash		
Special Handling	Do Not Mail		
Agency Ref			
Advertiser Ref			
Product 1			
Product 2			

Billing Address:

**WPGX-Public Service**  
**Attention: Accounts Payable**  
**XXXX**  
**XXXX, XX XXXXX**

Send Payment To:

**WPGX-TV**  
**3914 Wistar Road**  
**Richmond, VA 23228**

Line	Start Date	End Date	Description	Start/End Time	MTWTFSS	Length	Spots/ Week	Rate	Type
1	08/23/20	12/31/24		5a-5x	MTWTFSS	:30	2	\$0.00	NM
Weeks: <u>Start Date</u> <u>End Date</u> <u>MTWTFSS</u> <u>Spots/Week</u> <u>Rate</u> 05/01/23 05/07/23 MTWTFSS 2 \$0.00									
Spots: # <u>Ch</u> <u>Day</u> <u>Air Date</u> <u>Air Time</u> <u>Description</u> <u>Start/End Time</u> <u>Length</u> <u>Ad-ID</u> <u>Rate</u> <u>Type</u> 283 WPGX M 05/01/23 4:59 AM 5a-5x :30 Panama City EEO :30 \$0.00 NM 284 WPGX Tu 05/02/23 2:31 PM 5a-5x :30 Panama City EEO :30 \$0.00 NM									
Weeks: <u>Start Date</u> <u>End Date</u> <u>MTWTFSS</u> <u>Spots/Week</u> <u>Rate</u> 05/08/23 05/14/23 MTWTFSS 2 \$0.00									
Spots: # <u>Ch</u> <u>Day</u> <u>Air Date</u> <u>Air Time</u> <u>Description</u> <u>Start/End Time</u> <u>Length</u> <u>Ad-ID</u> <u>Rate</u> <u>Type</u> 285 WPGX M 05/08/23 2:10 AM 5a-5x :30 Panama City EEO :30 \$0.00 NM 286 WPGX Tu 05/09/23 2:20 AM 5a-5x :30 Panama City EEO :30 \$0.00 NM									
Weeks: <u>Start Date</u> <u>End Date</u> <u>MTWTFSS</u> <u>Spots/Week</u> <u>Rate</u> 05/15/23 05/21/23 MTWTFSS 2 \$0.00									
Spots: # <u>Ch</u> <u>Day</u> <u>Air Date</u> <u>Air Time</u> <u>Description</u> <u>Start/End Time</u> <u>Length</u> <u>Ad-ID</u> <u>Rate</u> <u>Type</u> 288 WPGX M 05/15/23 4:29 AM 5a-5x :30 Panama City EEO :30 \$0.00 NM 287 WPGX Tu 05/16/23 2:29 AM 5a-5x :30 Panama City EEO :30 \$0.00 NM									
Weeks: <u>Start Date</u> <u>End Date</u> <u>MTWTFSS</u> <u>Spots/Week</u> <u>Rate</u> 05/22/23 05/28/23 MTWTFSS 2 \$0.00									
Spots: # <u>Ch</u> <u>Day</u> <u>Air Date</u> <u>Air Time</u> <u>Description</u> <u>Start/End Time</u> <u>Length</u> <u>Ad-ID</u> <u>Rate</u> <u>Type</u> 290 WPGX M 05/22/23 1:57 AM 5a-5x :30 Panama City EEO :30 \$0.00 NM 289 WPGX Tu 05/23/23 1:31 AM 5a-5x :30 Panama City EEO :30 \$0.00 NM									

**Total Spots 8**

## Payment Terms 30 Days

Net Total **\$0.00**

Invoice Balance as of 04/18/24 12:46:05 PM ET **\$0.00**

We warrant that the actual broadcast information shown on this invoice was taken from the program log. Lockwood Broadcast Group does not discriminate in its advertising contracts, and it will not accept advertising intended to discriminate on the basis of race or ethnicity. Advertiser hereto affirms that nothing in this Agreement is intended to discriminate on the basis of race or ethnicity.

# INVOICE



**WPGX-TV**  
**700 W 23rd St #28**  
**Panama City, FL 32405**  
**Main: (804) 672-6565**  
**Billing: (804) 672-6565**

Property	WPGX		
Invoice #	122020-35	Order #	122020
Invoice Date	06/25/23	Alt Order #	
Invoice Month	June 2023	Deal #	
Invoice Period	05/29/23 - 06/25/23	Flight Dates	08/23/20 - 12/31/24
Advertiser	WPGX-Public Service		
Product	Compliance - EEO		
Estimate #	Compliance - EEO		
Account Executive	WPGX House		
Sales Office	Panama City Local		
Sales Region	Local		
Agency Code			
Advertiser Code			
Billing Calendar	Broadcast		
Billing Type	Cash		
Special Handling	Do Not Mail		
Agency Ref			
Advertiser Ref			
Product 1			
Product 2			

Billing Address:

**WPGX-Public Service**  
**Attention: Accounts Payable**  
**XXXX**  
**XXXX, XX XXXXX**

Send Payment To:

**WPGX-TV**  
**3914 Wistar Road**  
**Richmond, VA 23228**

Line	Start Date	End Date	Description	Start/End Time	MTWTFSS	Length	Spots/ Week	Rate	Type
1	08/23/20	12/31/24		5a-5x	MTWTFSS	:30	2	\$0.00	NM
Weeks: <u>Start Date</u> <u>End Date</u> <u>MTWTFSS</u> <u>Spots/Week</u> <u>Rate</u> 05/29/23 06/04/23 MTWTFSS 2 \$0.00									
Spots: # <u>Ch</u> <u>Day</u> <u>Air Date</u> <u>Air Time</u> <u>Description</u> <u>Start/End Time</u> <u>Length</u> <u>Ad-ID</u> <u>Rate</u> <u>Type</u> 291 WPGX M 05/29/23 2:20 AM 5a-5x :30 Panama City EEO :30 \$0.00 NM 292 WPGX Tu 05/30/23 3:29 AM 5a-5x :30 Panama City EEO :30 \$0.00 NM									
Weeks: <u>Start Date</u> <u>End Date</u> <u>MTWTFSS</u> <u>Spots/Week</u> <u>Rate</u> 06/05/23 06/11/23 MTWTFSS 2 \$0.00									
Spots: # <u>Ch</u> <u>Day</u> <u>Air Date</u> <u>Air Time</u> <u>Description</u> <u>Start/End Time</u> <u>Length</u> <u>Ad-ID</u> <u>Rate</u> <u>Type</u> 293 WPGX M 06/05/23 1:23 AM 5a-5x :30 Panama City EEO :30 \$0.00 NM 294 WPGX Tu 06/06/23 2:25 AM 5a-5x :30 Panama City EEO :30 \$0.00 NM									
Weeks: <u>Start Date</u> <u>End Date</u> <u>MTWTFSS</u> <u>Spots/Week</u> <u>Rate</u> 06/12/23 06/18/23 MTWTFSS 2 \$0.00									
Spots: # <u>Ch</u> <u>Day</u> <u>Air Date</u> <u>Air Time</u> <u>Description</u> <u>Start/End Time</u> <u>Length</u> <u>Ad-ID</u> <u>Rate</u> <u>Type</u> 296 WPGX M 06/12/23 4:29 AM 5a-5x :30 Panama City EEO :30 \$0.00 NM 295 WPGX Sa 06/17/23 2:45 AM 5a-5x :30 Panama City EEO :30 \$0.00 NM									
Weeks: <u>Start Date</u> <u>End Date</u> <u>MTWTFSS</u> <u>Spots/Week</u> <u>Rate</u> 06/19/23 06/25/23 MTWTFSS 2 \$0.00									
Spots: # <u>Ch</u> <u>Day</u> <u>Air Date</u> <u>Air Time</u> <u>Description</u> <u>Start/End Time</u> <u>Length</u> <u>Ad-ID</u> <u>Rate</u> <u>Type</u> 297 WPGX Th 06/22/23 1:42 AM 5a-5x :30 Panama City EEO :30 \$0.00 NM 298 WPGX Su 06/25/23 1:29 AM 5a-5x :30 Panama City EEO :30 \$0.00 NM									

**Total Spots 8**

## Payment Terms 30 Days

Net Total **\$0.00**

Invoice Balance as of 04/18/24 12:46:18 PM ET **\$0.00**

We warrant that the actual broadcast information shown on this invoice was taken from the program log. Lockwood Broadcast Group does not discriminate in its advertising contracts, and it will not accept advertising intended to discriminate on the basis of race or ethnicity. Advertiser hereto affirms that nothing in this Agreement is intended to discriminate on the basis of race or ethnicity.

# INVOICE



**WPGX-TV**  
**700 W 23rd St #28**  
**Panama City, FL 32405**  
**Main: (804) 672-6565**  
**Billing: (804) 672-6565**

Property	WPGX		
Invoice #	122020-36	Order #	122020
Invoice Date	07/30/23	Alt Order #	
Invoice Month	July 2023	Deal #	
Invoice Period	06/26/23 - 07/30/23	Flight Dates	08/23/20 - 12/31/24
Advertiser	WPGX-Public Service		
Product	Compliance - EEO		
Estimate #	Compliance - EEO		
Account Executive	WPGX House		
Sales Office	Panama City Local		
Sales Region	Local		
Agency Code			
Advertiser Code			
Billing Calendar	Broadcast		
Billing Type	Cash		
Special Handling	Do Not Mail		
Agency Ref			
Advertiser Ref			
Product 1			
Product 2			

Billing Address:

**WPGX-Public Service**  
**Attention: Accounts Payable**  
**XXXX**  
**XXXX, XX XXXXX**

Send Payment To:

**WPGX-TV**  
**3914 Wistar Road**  
**Richmond, VA 23228**

Line	Start Date	End Date	Description	Start/End Time	MTWTFSS	Length	Spots/ Week	Rate	Type
1	08/23/20	12/31/24		5a-5x	MTWTFSS	:30	2	\$0.00	NM
Weeks: <u>Start Date</u> <u>End Date</u> <u>MTWTFSS</u> <u>Spots/Week</u> <u>Rate</u> 06/26/23 07/02/23 MTWTFSS 2 \$0.00									
Spots: # <u>Ch</u> <u>Day</u> <u>Air Date</u> <u>Air Time</u> <u>Description</u> <u>Start/End Time</u> <u>Length</u> <u>Ad-ID</u> <u>Rate</u> <u>Type</u> 299 WPGX M 06/26/23 2:09 AM 5a-5x :30 Panama City EEO :30 \$0.00 NM 300 WPGX Tu 06/27/23 1:12 AM 5a-5x :30 Panama City EEO :30 \$0.00 NM									
Weeks: <u>Start Date</u> <u>End Date</u> <u>MTWTFSS</u> <u>Spots/Week</u> <u>Rate</u> 07/03/23 07/09/23 MTWTFSS 2 \$0.00									
Spots: # <u>Ch</u> <u>Day</u> <u>Air Date</u> <u>Air Time</u> <u>Description</u> <u>Start/End Time</u> <u>Length</u> <u>Ad-ID</u> <u>Rate</u> <u>Type</u> 301 WPGX M 07/03/23 1:50 AM 5a-5x :30 Panama City EEO :30 \$0.00 NM 302 WPGX F 07/07/23 2:59 AM 5a-5x :30 Panama City EEO :30 \$0.00 NM									
Weeks: <u>Start Date</u> <u>End Date</u> <u>MTWTFSS</u> <u>Spots/Week</u> <u>Rate</u> 07/10/23 07/16/23 MTWTFSS 2 \$0.00									
Spots: # <u>Ch</u> <u>Day</u> <u>Air Date</u> <u>Air Time</u> <u>Description</u> <u>Start/End Time</u> <u>Length</u> <u>Ad-ID</u> <u>Rate</u> <u>Type</u> 304 WPGX Th 07/13/23 1:41 AM 5a-5x :30 Panama City EEO :30 \$0.00 NM 303 WPGX Su 07/16/23 3:29 AM 5a-5x :30 Panama City EEO :30 \$0.00 NM									
Weeks: <u>Start Date</u> <u>End Date</u> <u>MTWTFSS</u> <u>Spots/Week</u> <u>Rate</u> 07/17/23 07/23/23 MTWTFSS 2 \$0.00									
Spots: # <u>Ch</u> <u>Day</u> <u>Air Date</u> <u>Air Time</u> <u>Description</u> <u>Start/End Time</u> <u>Length</u> <u>Ad-ID</u> <u>Rate</u> <u>Type</u> 305 WPGX M 07/17/23 1:57 AM 5a-5x :30 Panama City EEO :30 \$0.00 NM 306 WPGX Tu 07/18/23 4:29 AM 5a-5x :30 Panama City EEO :30 \$0.00 NM									
Weeks: <u>Start Date</u> <u>End Date</u> <u>MTWTFSS</u> <u>Spots/Week</u> <u>Rate</u> 07/24/23 07/30/23 MTWTFSS 2 \$0.00									
Spots: # <u>Ch</u> <u>Day</u> <u>Air Date</u> <u>Air Time</u> <u>Description</u> <u>Start/End Time</u> <u>Length</u> <u>Ad-ID</u> <u>Rate</u> <u>Type</u> 307 WPGX M 07/24/23 2:29 AM 5a-5x :30 Panama City EEO :30 \$0.00 NM 308 WPGX Tu 07/25/23 8:47 AM 5a-5x :30 Panama City EEO :30 \$0.00 NM									

**Total Spots 10**

## Payment Terms 30 Days

**Net Total \$0.00**

**Invoice Balance as of 04/18/24 12:46:29 PM ET \$0.00**

We warrant that the actual broadcast information shown on this invoice was taken from the program log. Lockwood Broadcast Group does not discriminate in its advertising contracts, and it will not accept advertising intended to discriminate on the basis of race or ethnicity. Advertiser hereto affirms that nothing in this Agreement is intended to discriminate on the basis of race or ethnicity.



# INVOICE



**WPGX-TV**  
**700 W 23rd St #28**  
**Panama City, FL 32405**  
**Main: (804) 672-6565**  
**Billing: (804) 672-6565**

Property	WPGX		
Invoice #	122020-37	Order #	122020
Invoice Date	08/27/23	Alt Order #	
Invoice Month	August 2023	Deal #	
Invoice Period	07/31/23 - 08/27/23	Flight Dates	08/23/20 - 12/31/24
Advertiser	WPGX-Public Service		
Product	Compliance - EEO		
Estimate #	Compliance - EEO		
Account Executive	WPGX House		
Sales Office	Panama City Local		
Sales Region	Local		
Agency Code			
Advertiser Code			
Billing Calendar	Broadcast		
Billing Type	Cash		
Special Handling	Do Not Mail		
Agency Ref			
Advertiser Ref			
Product 1			
Product 2			

Billing Address:

**WPGX-Public Service**  
**Attention: Accounts Payable**  
**XXXX**  
**XXXX, XX XXXXX**

Send Payment To:

**WPGX-TV**  
**3914 Wistar Road**  
**Richmond, VA 23228**

Line	Start Date	End Date	Description	Start/End Time	MTWTFSS	Length	Spots/ Week	Rate	Type
1	08/23/20	12/31/24		5a-5x	MTWTFSS	:30	2	\$0.00	NM
Weeks: <u>Start Date</u> <u>End Date</u> <u>MTWTFSS</u> <u>Spots/Week</u> <u>Rate</u> 07/31/23 08/06/23 MTWTFSS 2 \$0.00									
Spots: # <u>Ch</u> <u>Day</u> <u>Air Date</u> <u>Air Time</u> <u>Description</u> <u>Start/End Time</u> <u>Length</u> <u>Ad-ID</u> <u>Rate</u> <u>Type</u> 310 WPGX F 08/04/23 1:49 AM 5a-5x :30 Panama City EEO :30 \$0.00 NM 309 WPGX Sa 08/05/23 11:43 PM 5a-5x :30 Panama City EEO :30 \$0.00 NM									
Weeks: <u>Start Date</u> <u>End Date</u> <u>MTWTFSS</u> <u>Spots/Week</u> <u>Rate</u> 08/07/23 08/13/23 MTWTFSS 2 \$0.00									
Spots: # <u>Ch</u> <u>Day</u> <u>Air Date</u> <u>Air Time</u> <u>Description</u> <u>Start/End Time</u> <u>Length</u> <u>Ad-ID</u> <u>Rate</u> <u>Type</u> 312 WPGX M 08/07/23 3:59 AM 5a-5x :30 Panama City EEO :30 \$0.00 NM 311 WPGX F 08/11/23 5:29 AM 5a-5x :30 Panama City EEO :30 \$0.00 NM									
Weeks: <u>Start Date</u> <u>End Date</u> <u>MTWTFSS</u> <u>Spots/Week</u> <u>Rate</u> 08/14/23 08/20/23 MTWTFSS 2 \$0.00									
Spots: # <u>Ch</u> <u>Day</u> <u>Air Date</u> <u>Air Time</u> <u>Description</u> <u>Start/End Time</u> <u>Length</u> <u>Ad-ID</u> <u>Rate</u> <u>Type</u> 314 WPGX M 08/14/23 11:13 PM 5a-5x :30 Panama City EEO :30 \$0.00 NM 313 WPGX Tu 08/15/23 2:25 AM 5a-5x :30 Panama City EEO :30 \$0.00 NM									
Weeks: <u>Start Date</u> <u>End Date</u> <u>MTWTFSS</u> <u>Spots/Week</u> <u>Rate</u> 08/21/23 08/27/23 MTWTFSS 2 \$0.00									
Spots: # <u>Ch</u> <u>Day</u> <u>Air Date</u> <u>Air Time</u> <u>Description</u> <u>Start/End Time</u> <u>Length</u> <u>Ad-ID</u> <u>Rate</u> <u>Type</u> 315 WPGX F 08/25/23 1:59 AM 5a-5x :30 Panama City EEO :30 \$0.00 NM 316 WPGX Sa 08/26/23 2:29 AM 5a-5x :30 Panama City EEO :30 \$0.00 NM									

**Total Spots 8**

## Payment Terms 30 Days

Net Total **\$0.00**

Invoice Balance as of 04/18/24 12:46:45 PM ET **\$0.00**

We warrant that the actual broadcast information shown on this invoice was taken from the program log. Lockwood Broadcast Group does not discriminate in its advertising contracts, and it will not accept advertising intended to discriminate on the basis of race or ethnicity. Advertiser hereto affirms that nothing in this Agreement is intended to discriminate on the basis of race or ethnicity.

# INVOICE



**WPGX-TV**  
**700 W 23rd St #28**  
**Panama City, FL 32405**  
**Main: (804) 672-6565**  
**Billing: (804) 672-6565**

Property	WPGX		
Invoice #	122020-38	Order #	122020
Invoice Date	09/24/23	Alt Order #	
Invoice Month	September 2023	Deal #	
Invoice Period	08/28/23 - 09/24/23	Flight Dates	08/23/20 - 12/31/24
Advertiser	WPGX-Public Service		
Product	Compliance - EEO		
Estimate #	Compliance - EEO		
Account Executive	WPGX House		
Sales Office	Panama City Local		
Sales Region	Local		
Agency Code			
Advertiser Code			
Billing Calendar	Broadcast		
Billing Type	Cash		
Special Handling	Do Not Mail		
Agency Ref			
Advertiser Ref			
Product 1			
Product 2			

Billing Address:

**WPGX-Public Service**  
**Attention: Accounts Payable**  
**XXXX**  
**XXXX, XX XXXXX**

Send Payment To:

**WPGX-TV**  
**3914 Wistar Road**  
**Richmond, VA 23228**

Line	Start Date	End Date	Description	Start/End Time	MTWTFSS	Length	Spots/ Week	Rate	Type
1	08/23/20	12/31/24		5a-5x	MTWTFSS	:30	2	\$0.00	NM
Weeks: <u>Start Date</u> <u>End Date</u> <u>MTWTFSS</u> <u>Spots/Week</u> <u>Rate</u> 08/28/23 09/03/23 MTWTFSS 2 \$0.00									
Spots: # <u>Ch</u> <u>Day</u> <u>Air Date</u> <u>Air Time</u> <u>Description</u> <u>Start/End Time</u> <u>Length</u> <u>Ad-ID</u> <u>Rate</u> <u>Type</u> 317 WPGX M 08/28/23 1:34 AM 5a-5x :30 Panama City EEO :30 \$0.00 NM 318 WPGX Tu 08/29/23 3:29 AM 5a-5x :30 Panama City EEO :30 \$0.00 NM									
Weeks: <u>Start Date</u> <u>End Date</u> <u>MTWTFSS</u> <u>Spots/Week</u> <u>Rate</u> 09/04/23 09/10/23 MTWTFSS 2 \$0.00									
Spots: # <u>Ch</u> <u>Day</u> <u>Air Date</u> <u>Air Time</u> <u>Description</u> <u>Start/End Time</u> <u>Length</u> <u>Ad-ID</u> <u>Rate</u> <u>Type</u> 320 WPGX M 09/04/23 12:25 AM 5a-5x :30 Panama City EEO :30 \$0.00 NM 319 WPGX Tu 09/05/23 3:29 AM 5a-5x :30 Panama City EEO :30 \$0.00 NM									
Weeks: <u>Start Date</u> <u>End Date</u> <u>MTWTFSS</u> <u>Spots/Week</u> <u>Rate</u> 09/11/23 09/17/23 MTWTFSS 2 \$0.00									
Spots: # <u>Ch</u> <u>Day</u> <u>Air Date</u> <u>Air Time</u> <u>Description</u> <u>Start/End Time</u> <u>Length</u> <u>Ad-ID</u> <u>Rate</u> <u>Type</u> 321 WPGX Tu 09/12/23 2:55 AM 5a-5x :30 Panama City EEO :30 \$0.00 NM 322 WPGX F 09/15/23 1:48 AM 5a-5x :30 Panama City EEO :30 \$0.00 NM									
Weeks: <u>Start Date</u> <u>End Date</u> <u>MTWTFSS</u> <u>Spots/Week</u> <u>Rate</u> 09/18/23 09/24/23 MTWTFSS 2 \$0.00									
Spots: # <u>Ch</u> <u>Day</u> <u>Air Date</u> <u>Air Time</u> <u>Description</u> <u>Start/End Time</u> <u>Length</u> <u>Ad-ID</u> <u>Rate</u> <u>Type</u> 323 WPGX M 09/18/23 2:55 AM 5a-5x :30 Panama City EEO :30 \$0.00 NM 324 WPGX Sa 09/23/23 3:20 AM 5a-5x :30 Panama City EEO :30 \$0.00 NM									

**Total Spots 8**

## Payment Terms 30 Days

<u>Net Total</u>	<b>\$0.00</b>
<u>Invoice Balance as of 04/18/24 12:46:59 PM ET</u>	<b>\$0.00</b>

We warrant that the actual broadcast information shown on this invoice was taken from the program log. Lockwood Broadcast Group does not discriminate in its advertising contracts, and it will not accept advertising intended to discriminate on the basis of race or ethnicity. Advertiser hereto affirms that nothing in this Agreement is intended to discriminate on the basis of race or ethnicity.

**Exhibit 6**

Documents Concerning Training of Station Personnel

[Attached]

## Tiffany Humphrey

---

**From:** Anne Dolan  
**Sent:** Friday, September 2, 2022 9:49 AM  
**To:** Tiffany Humphrey; Shawna Greene  
**Cc:** Shawna Greene  
**Subject:** RE: Annual EEO report  
**Attachments:** copier@wpgxfox28.com\_20220902\_084735.pdf

Hi Tiffany,

At WPGX we did WO Marketplace training.

Shawna did training with a new AE (Heavyn) to give her a refresher after not being in the business for a few years.

All AE's did training in several categories in JDA such as prospecting, closing and new business.

We have the training materials for Marketplace, but the other trainings were web based.

Please let me know if you need more detail.

Thanks,

Anne

---

**From:** Tiffany Humphrey <tiffany@lockwoodbroadcast.com>  
**Sent:** Thursday, September 1, 2022 9:07 AM  
**To:** Anne Dolan <ADolan@wpgxfox28.com>; Shawna Greene <SGreene@wpgxfox28.com>  
**Subject:** Annual EEO report

Hi there!

Your report is due at the end of this month. Have you done any trainings this year that I may record for the menu options?

Thanks!

**From:** [Shawna Greene](#)  
**Mail received time:** Fri, 2 Sep 2022 10:46:47  
**Sent:** Fri, 2 Sep 2022 10:46:47  
**To:** [Tiffany Humphrey](#)  
**Cc:** [Anne Dolan](#)  
**Subject:** FW: Emailing: JDA Training.jpg  
**Importance:** Normal  
**Sensitivity:** None  
**Attachments:** [JDA Training.jpg](#); [SnipImage.JPG](#);  
**Archived:** Friday, May 3, 2024 10:56:27 AM

---

Hi Tiffany,













In the attachment are a couple of the reports that I was able to pull.

















The first classes started on Jan. 3rd.  
Then each month to follow.

All A.E's were required to take this. The only one that was slacking was [REDACTED]  
A.E's

Shawna Greene  
General Sales Manager  
[shgreene@wpgxfox28.com](mailto:shgreene@wpgxfox28.com)

700 West 23rd St. C-28  
Panama City, Fl. 32405  
Direct Line 850- 215-6495  
Main Line 850-215-6500

Category Name	Course Name	Progress	Course Status
Selling Through Adversity	<a href="#">Five Star Prospecting</a>	3 of 3	 Complete
Selling Through Adversity	<a href="#">30 Point Prospecting System</a>	3 of 3	 Complete
New Sellers	<a href="#">Why It's A Great Time To Join Our Industry</a>	0 of 3	 In Progress
New Sellers	<a href="#">Prospecting New Business</a>	4 of 4	 Complete
New Sellers	<a href="#">Getting The Appointment</a>	4 of 4	 Complete
New Sellers	<a href="#">Mastering the Initial Diagnosis Call</a>	6 of 6	 Complete
New Sellers	<a href="#">The 10 Must Ask Diagnosis Questions</a>	6 of 6	 Complete
New Sellers	<a href="#">Dealing with Objections</a>	4 of 4	 Complete
New Sellers	<a href="#">Jump Starting Your Career</a>	1 of 1	 Complete
Experienced Sellers	<a href="#">Closing</a>	3 of 3	 Complete
Experienced Sellers	<a href="#">Reduce Churn</a>	3 of 3	 Complete
Experienced Sellers	<a href="#">Avoid These Common Mistakes</a>	6 of 6	 Complete

<input type="checkbox"/>	Due Date 	Status	Assignment Name	Courses	Users	Locations	Action
<input type="checkbox"/>	 07/30/2022	expired	<b>Prospecting 30 points and 5 Star</b> Created by Shawna Greene (4) at WPGX - Panama - Lockwood on 07/06/2022	2	4	1	 
<input type="checkbox"/>	 04/16/2022	expired	<b>Closing</b> Created by Shawna Greene (4) at WPGX - Panama - Lockwood on 03/30/2022	1	3	1	 
<input type="checkbox"/>	 03/19/2022	expired	<b>Reduce Churn/Mistakes</b> Created by Shawna Greene (4) at WPGX - Panama - Lockwood on 02/25/2022	2	3	1	 
<input type="checkbox"/>	 01/21/2022	expired	<b>Prospecting</b> Created by Shawna Greene (4) at WPGX - Panama - Lockwood on 01/03/2022	1	3	1	 
<input type="checkbox"/>	 12/31/2021	expired	<b>VBR</b> Created by Managers Demo (4) at WPGX - Panama - Lockwood on 12/16/2021	1	1	1	 

## Tiffany Humphrey

---

**From:** Donna Giancola  
**Sent:** Monday, May 15, 2023 11:20 AM  
**To:** LBNOC\_Business  
**Cc:** Shawna Greene; Anne Dolan  
**Subject:** WPGX - FCC 2022-2023 EEO Report - Training Info  
**Attachments:** Auto Pitch Deck shortened.pptx; White Label Deck.pptx; Station Rate Card\_compressed (1).pdf; Jason Schlitz Training Travel Receipt.pdf; FW: Digital Appointments

For the record:

WPGX Sales Team had the following training:

3/29/23 – Jason Schlitz – Orbit Interactive – Digital Training Session – attachments:

- Training Slide Decks
- Jason Schlitz’s Travel receipt
- Emails for customer visits after digital training

Regards,

*Donna Giancola*

Business Office Coordinator

WPGX-TV

700 West 23<sup>rd</sup> Street, Suite C-28

Panama City, FL 32405

(850) 215-6500 (office) option 3



**Paying by credit card go to:** <https://www.lockwoodbroadcast.com/payportal/>

This message and any attachments may contain confidential and privileged information. If you are not the intended recipient, any disclosure, copying, distribution, or use of any information contained in this message or any attachment is prohibited. If you have received this message in error, please do not read, copy, or forward. Also, please permanently delete all copies and any attachments and notify the sender immediately by replying to the message





## 8/25/23 Agenda

- 1) Intro
- 2) The Why
- 3) The Opportunity
- 4) The Contest
- 5) Sample Packages
- 6) Next week preview



Orbit  
INTERACTIVE  
www.orbitinteractive.com

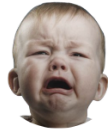

**Richard Harris**

VP of Digital Happiness  
757-513-7079



Orbit  
INTERACTIVE  
www.orbitinteractive.com



**Jason Schlitz**

Sr. Digital Development Director  
316-249-8919



Orbit  
INTERACTIVE  
www.orbitinteractive.com



**Mini K**

Senior Account Manager  
321-247-7313



Orbit  
INTERACTIVE  
www.orbitinteractive.com



**Elijah Pinket**

Senior Account Manager  
760-577-0897



Orbit  
INTERACTIVE  
www.orbitinteractive.com



**Brittany Comeau**

Senior Account Manager  
(386)-690-1240



Orbit  
INTERACTIVE  
www.orbitinteractive.com



**Ryan Grigg**

Junior Account Manager  
305-495-0421





## 9/8/23 Agenda

- 1) Schlitzkrieg! Recap and update.
- 2) Order entry walkthrough
- 3) Basic dashboard navigation
- 4) AI Tool – any questions?
- 5) Next week preview



## 9/15/23 Agenda

- 1) Success Story!
- 2) Product Training – Display Products and Conversions
- 3) Schlitzkrieg! Recap and update.
- 4) No training next week – Schlitz is incommunicado starting next Tue 9/19 thru Sun 9/24.

# GROW YOUR BUSINESS

## Understanding Major Media and the Best Allocation of your Marketing Dollar

*We will discuss Independent Research and Strategies for Broadcast TV, Digital, Cable, Social Media, Radio and Billboards*



**When** *October 17<sup>th</sup>*  
*Registration starts at 11:30am*  
*Lunch: 12:00 pm – 1:00 pm*

**Where** *Runaway Island Restaurant*  
*14521 Front Beach Road,*  
*Panama City Beach, FL 324*

**RSVP** *AE name*  
*AE phone*  
*AEemail@wpgxfox28.com*



*Presented by*

